

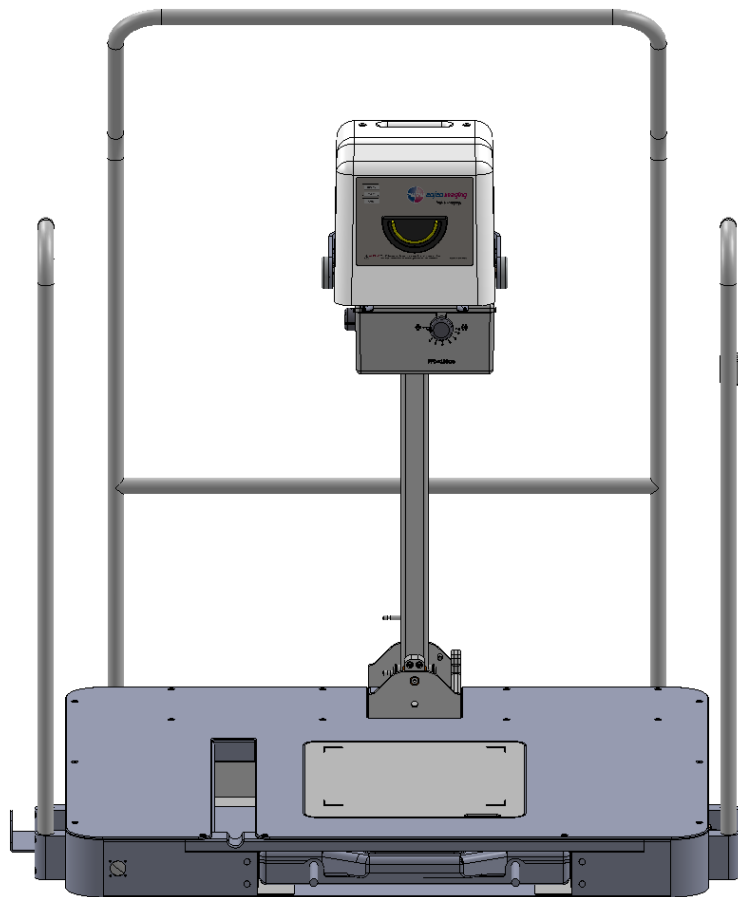


PXS-710D

Podiatry X-Ray Source

Installation/Operation Manual

(Revision 5, S/N 312 ...)



Source-Ray, Inc.
50 Fleetwood Ct., Ronkonkoma, NY 11779
631-244-8200, 631- 244-7464 (Fax)

REVISION CONTROL

Rev	Description	Initiated By	Date	Approved By	Date
0	Initial Release	Martin E.	11/25/13	R. Manez	12/20/13
1	Corrected typos	Ray M.	12/4/14	V. Milonas	12/5/14
2	Updated Fig 3.5, Corrected callout ID's	Martin E.	1/13/15	V. Milonas	1/13/15
3	Updated un-packaging procedure	Steven L.	2/6/15	R. Manez	2/6/15
4	Updated drawings for yoke pivot	Steven L.	5/5/15	R. Manez	5/6/15
5	DCR 1198	Steven L.	11/01/16	R. Manez	2/16/17

SECTION**PAGE**

I	<u>GENERAL INFORMATION</u>	
1.1	Introduction	7
1.2	Description	7
1.3	Important Notice	7
1.4	Responsibilities	9
1.5	Electromagnetic Compatibility Warnings & Declarations	10
1.6	Compliance Notice	15
1.7	Safety Standards	15
1.8	Electrical Specifications	16
1.9	X-ray Tube Characteristics	18
1.10	X-ray Collimator	23
1.11	Mechanical Specification	23
1.12	Equipment Classification	25
II	<u>INSTALLATION AND CALIBRATION</u>	
2.1	Un-Packaging	28
2.2	Assembly	30
2.3	Electrical Connections	32
2.4	Calibration Set-Up	33
2.5	Tube Potential (kVp) & Beam Current (mA)	33
2.6	mAs	43
2.7	Beam Alignment	44
III	<u>UNIT OPERATION</u>	
3.1	Controls and Indicators (Control Panel)	45
3.2	Source Base	49
3.3	Operating Procedure (Generator/Control Assembly)	54
3.4	Faults	55
3.5	Procedure	56
IV	<u>THEORY OF OPERATION</u>	
4.1	Source Overview	60
4.2	Generator/Control Assembly	60
4.3	OpalRad Inverter Assembly	62
V	<u>UNIT MAINTENANCE</u>	<u>PAGE</u>
5.1	Introduction	66
5.2	Recommended Intervals	66
5.3	Ordering Information	67
5.4	Maintenance Procedure	67
5.5	Warm-Up Procedure	67

LIST OF FIGURES

<u>FIGURE</u>	<u>DESCRIPTION</u>	<u>PAGE</u>
1.1	Tube Characteristics	20
1.2	X-Ray Tube Ratings Chart	21
1.3	X-ray Head Heating Chart	22
1.4	X-ray Head Cooling Chart	22
1.5	Collimator Front View	24
1.6	Collimator Side View	24
1.7	Focal Spot Location	25
1.8	Source Dimensions	26
1.9	Zone Of Occupancy	27
2.1	Anchor Points	30
2.2	Handrail Assembly	31
2.3	View Menu	36
2.4	Password Dialog Box	37
2.5	Calibration Menu	37
2.6	Calibration Wizard	38
2.7	Settings Confirmation	39
2.8	Settings Saved Confirmation	40
2.9	Application Exit	40
2.10	Calibration Mode Selection	41
2.11	Calibration Mode Utility	42
2.12	Ready Indicator	42
2.13	X-ray Indicator	43
3.1	Generator/Control Connector Description	47
3.2	Optional Remote Control Panel Description	47
3.3	Control Panel Description	48
3.4	Hand Switch Assembly	48
3.5	Source Front View	50
3.6	Source Side View (0° Head Tilt)	51
3.7	Source Side View (15° Head Tilt)	51
3.8	Source Base (Rear Control Panel)	53
3.9	Source Base (Side Control Panel)	53
3.18	OpalRad Ready Time Display	60





LIST OF TABLES

<u>TABLE</u>	<u>DESCRIPTION</u>	<u>PAGE</u>
1.1	Emissions & Immunity Chart	13
3.1	mAs Increments Chart	48
3.2	Technique Chart	57
4.1	Approved 3 rd Party Control Software	62
4.2	RS-232 Pin Out	63
4.3	Generator OpalRad Communications	65
5.1	Maintenance Checklist (Every 6 Months)	68
5.2	Displayed Fault Conditions	69

LIST OF SCHEMATICS

<u>SCHEMATIC</u>	<u>DESCRIPTION</u>	<u>PAGE</u>
5.1	Base Wiring Diagram	70
5.2	Generator Wiring Diagram	71

LIST OF SYMBOLS

SYMBOL	DESCRIPTION
	Exposure Switch
	Type "B" Applied Part
	Protective Earth
	Caution
	Pinch Point, Keep Hands Clear
	Warning- Electric Shock Hazard, Keep Hands Clear
	Refer to Instruction Manual
	Operator's Manual; Operating Instructions
	Prescription Use (Part 21 CFR 801 Subpart D)

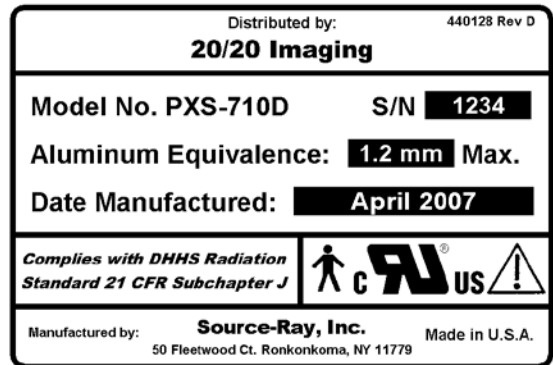
PXS-710D

LABELS

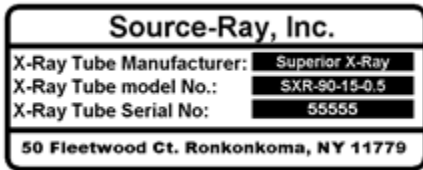
TABLE OF CONTENTS



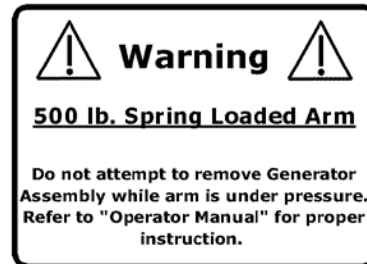
LABEL "A"



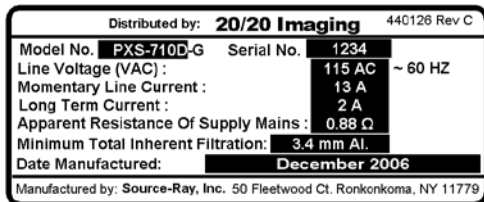
LABEL "B"



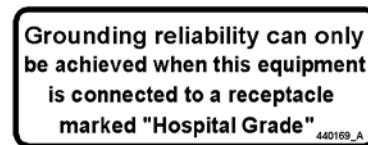
LABEL "C"



LABEL "D"



LABEL "E"



LABEL "F"



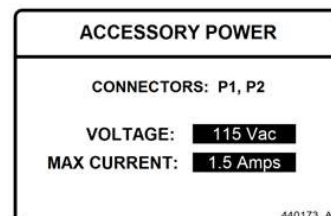
LABEL "G"



LABEL "H"



LABEL "T"



LABEL "J"

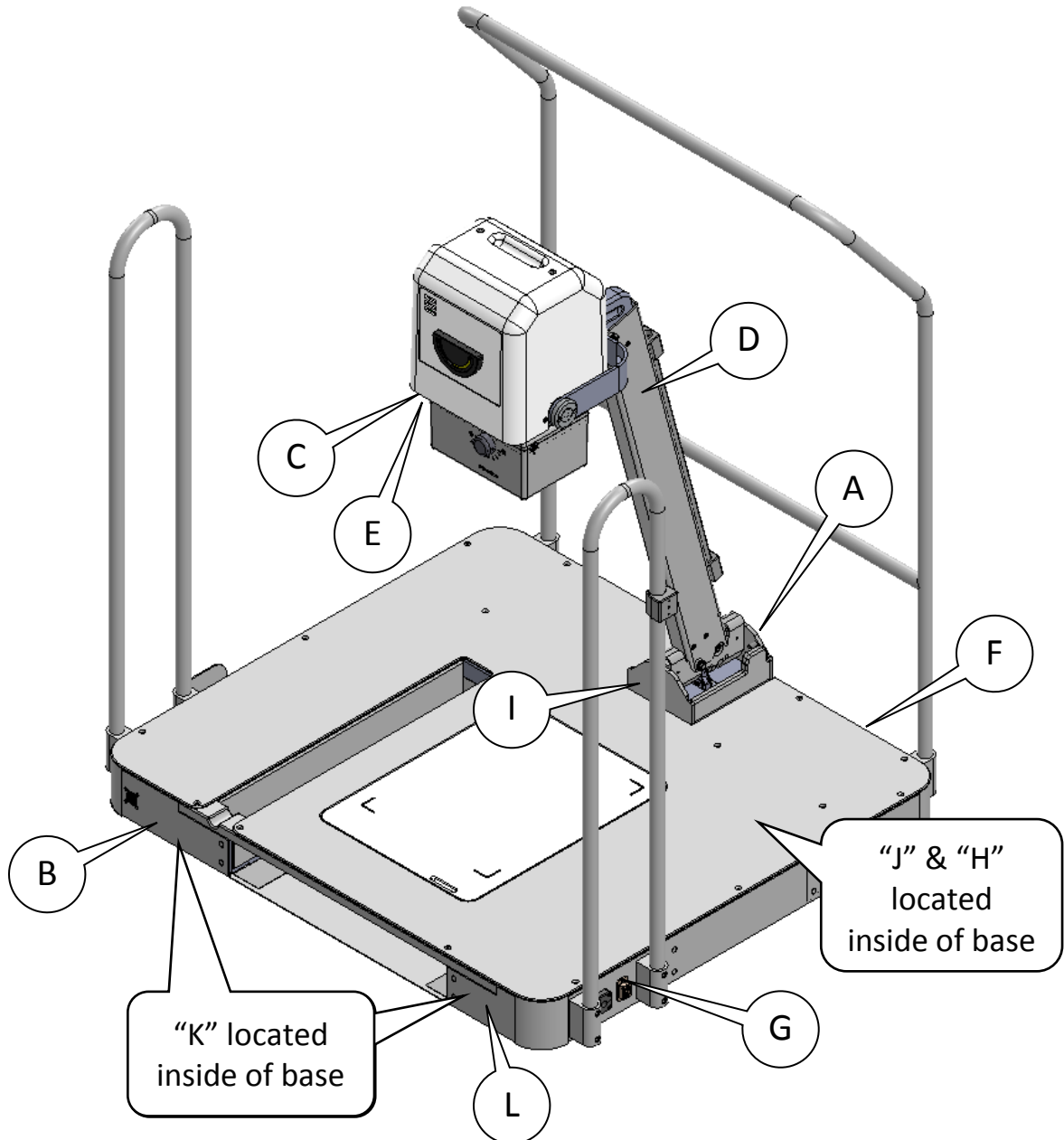
Base Mounting Hole
440174_A

LABEL "K"

BASE PLATFORM	440178_A
Weight Capacity:	300 LBS, 136 KG
FOOT PLATE	
Material:	TECAPRO MT
Center Thickness:	0.375", 9.5mm

LABEL "L"

LABEL LOCATIONS



GENERAL INFORMATION**1.1 INTRODUCTION**

This manual is divided into five sections and contains the following information: Section I describes general information. Section II contains installation and calibration procedures. Section III contains operating procedures and technique guides. Section IV discusses theory of operation and Section V contains maintenance procedures and recommended intervals.

1.2 DESCRIPTION

The PXS-710D Podiatry X-Ray source is designed and manufactured by Source-Ray, Inc. It provides a high quality radiographic capability in a small lightweight format. The source consists of the following major assemblies:

- X-Ray Generator/ Tube Housing
- X-Ray Remote Control Module (Optional)
- Podiatry Support Platform

1.3 IMPORTANT NOTICE

- The equipment manufactured by Source-Ray, Inc. and covered in this manual will function properly when operated, maintained, and repaired in accordance with the instructions in this manual. Source-Ray, Inc. does not assume responsibility for any malfunctioning of this equipment resulting from improper operation, maintenance, repair, or modification of its components.
- Keep this Operating Manual with the machine at all times and periodically review Important Notice's and the Operating & Safety Instructions.
- This manual should be carefully studied prior to use of the Podiatry X-ray Source and the instructions within should be always followed to assure safe continued usage.
- The contents of this manual should be thoroughly read and understood prior to attempting to put this X-Ray Source into operation.

1.3 CONTINUED:

- This equipment is sold to be used exclusively by or under the prescribed direction of a person who is licensed by law to operate equipment of this nature.
- The PXS-710D contains no user serviceable parts.
- Only qualified and authorized personnel shall operate this source. In this context, qualified means those legally permitted to operate this equipment in the jurisdiction in which the equipment is being used, and authorized means those authorized by the authority controlling the use of the equipment. Full use must be made of all radiation protection features, devices, sources, procedures, and accessories.
- **Zone of Occupancy:** During X-ray exposure personnel should be located in a safe distance outside the X-ray field, governed by the regulations and requirements of every state.
- Any procedure involving taking x-ray exposures must comply with federal and local regulations. X-ray can be harmful unless proper precaution and safety procedures are adhered to.
- Trained personnel operating this unit should be familiar with the Recommendations of the International Commission on Radiological Protection, contained in Annals of the ICRP with the applicable National Standards and should have been trained in the use of the equipment. The operator should use the largest possible focal spot to skin distance in order to keep the absorbed dose as low as reasonably achievable.
- This X-ray source may be dangerous to patient and operator unless safe exposure factors, operating instructions and maintenance schedules are observed.
- This source is designed to take x-rays of the lower extremities (foot and ankle). Do not jump or bounce on the foot rest area. Do not lift the unit by the Patient Assist Handles. Handles are meant for additional patient assist only.
- The boom arm presents a pinch hazard. Keep hands clear when in use.

1.4 RESPONSIBILITIES

- To operate X-ray equipment it is required by state/country that the operator will be trained personnel. The operator must be familiar with safety requirements for operating the X-ray generator.
- It is the responsibility of the operator to ensure the safety of the patient during exposure via proper positioning of the x-ray source.
- This equipment can be hazardous to both patient and operator unless established safe exposure factors, operating instructions, and maintenance schedules are observed. Source-Ray, Inc. disclaims all responsibility from any injury resulting from improper application of this equipment.
- Ensure that all personnel authorized to use the unit are aware of the danger of excessive exposure to X-ray radiation.
- The unit herein described is sold with the understanding that the manufacturer, its agents and representatives are NOT liable for injury or damage which may result from over-exposure of patients or personnel to X-ray radiation.
- The manufacturer does not accept any responsibility for over-exposure of patients or personnel to X-ray radiation generated by this unit which is a result of poor operating techniques or procedures.
- The manufacturer of this unit does not assume any responsibility for any equipment that has not been serviced and maintained in accordance with the manufacturer instructions or which has been modified or tampered with in any way.
- It is the responsibility of the operator to ensure the safety of the patient while the X-ray unit is in operation by visual observation, proper patient positioning and use of the devices that are intended to prevent patient injury.
- The unit has been designed to be used and installed on a flat surface as a fixed unit that stays in place with no wheels.
- It is the responsibility of the operator to always watch all parts of the unit to verify that there is neither interference nor possibility of collision with the patient or with other equipment.

1.4 CONTINUED:

- **Responsible organizations** (e.g. X-ray System Integrators) combining imaging components or accessories with the PXS-710D are required to insure the resulting system meets the requirements of ANSI/AAME ES 60601-1 and the standards identified in section 1.7.
- **Maximum Permissible Dose (MPD):** Make sure that the X-ray generator is set in working position with the reference axis (X-ray beam) pointing to the reception area. The operator shall use the largest possible focal spot to skin distance in order to keep the absorbed dose as low as reasonably achievable. Trained personnel operating this unit should be familiar with the Recommendations of the International Commission on Radiological Protection, contained in Annals Number 60 of the ICRP with the applicable National Standards and should have been trained in use of the equipment.

1.5 ELECTROMAGNETIC COMPATIBILITY WARNINGS & DECLARATIONS**1.5.1 INSTRUCTIONS FOR USE***[ENVIRONMENTS]*

The PXS-710D is intended for use in a Professional Health Care Facility. The PXS-710D may cause radio interference or may disrupt the operation of nearby equipment. It may be necessary to take mitigation measures, such as additional shielding or relocating or re-orienting the equipment.

1.5.1 CONTINUED:*[ESSENTIAL PERFORMANCE]*

The ME Equipment, PXS-710D, shall be able to perform its Essential Performance and remain safe. The following degradation associated with Essential Performance shall not be allowed:

- Expose Loading Parameters KV, mA, Time and mAs set on the operator control panel (OCP) shall not be different than actual output of X-Ray generator KV, mA and mAs, Time. (Within tolerance of each loading parameter)
- Reproducibility and Linearity of radiation output shall meet IEC 60601-2-54 requirement.
- The X-ray Generator shall protect the X-Ray tube exceeding its safety limits required by tube manufacture.
- With customer supplied Digital Imaging Panels: Performance of the PXS-710D shall provide image quality acceptable for medical diagnostic. The PXS-710D is designed to power one Digital Imaging Panel at a time.

“WARNING: Use of this equipment adjacent to or stacked with other equipment should be avoided because it could result in improper operation. If such use is necessary, this equipment and the other equipment should be observed to verify that they are operating normally.”

1.5.1 CONTINUED:

[LIST OF CABLES AND LENGTHS]

<u>DESCRIPTION</u>	<u>P/N</u>	<u>LENGTH</u>
AC Power Cable	560021	12ft
Exposure Switch	910007	12ft

“WARNING: Use of accessories, transducers and cables other than those specified or provided by the manufacturer of this equipment could result in increased electromagnetic emissions or decreased electromagnetic immunity of this equipment and result in improper operation.”

“WARNING: Portable RF communications equipment (including peripherals such as antenna cables and external antennas) should be used no closer than 30 cm (12 inches) to any part of the PXS-710D, including cables specified by the manufacturer. Otherwise, degradation of the performance of this equipment could result.”

NOTE: The EMISSIONS characteristics of this equipment make it suitable for use in industrial areas and hospitals (CISPR 11 class A). If it is used in a residential environment (for which CISPR 11 class B is normally required) this equipment might not offer adequate protection to radio-frequency communication services. The user might need to take mitigation measures, such as relocating or re-orienting the equipment.

TABLE 1.1
EMISSIONS & IMMUNITY CHART

Emissions and Immunity Test Standards Compliance																														
Emissions test	Compliance	Immunity Test Level (Professional Health Care Facility)																												
RF emissions CISPR 11	Group 1	<p style="text-align: center;">Conducted Emissions</p> <table border="1"> <thead> <tr> <th rowspan="2">Frequency Range</th> <th colspan="2">Group 1, Class A Limit [dBuV]</th> </tr> <tr> <th>Quasi Peak</th> <th>Average</th> </tr> </thead> <tbody> <tr> <td>0.15 to 0.50</td> <td>79.0</td> <td>66.0</td> </tr> <tr> <td>0.50 to 5.00</td> <td>73.0</td> <td>60.0</td> </tr> <tr> <td>5.00 to 30.0</td> <td>73.0</td> <td>60.0</td> </tr> </tbody> </table> <p style="text-align: center;">The lower limit applies at all transition frequencies.</p>	Frequency Range	Group 1, Class A Limit [dBuV]		Quasi Peak	Average	0.15 to 0.50	79.0	66.0	0.50 to 5.00	73.0	60.0	5.00 to 30.0	73.0	60.0														
Frequency Range	Group 1, Class A Limit [dBuV]																													
	Quasi Peak	Average																												
0.15 to 0.50	79.0	66.0																												
0.50 to 5.00	73.0	60.0																												
5.00 to 30.0	73.0	60.0																												
RF emissions CISPR 11	Class A	<p style="text-align: center;">Radiated Emissions</p> <table border="1"> <thead> <tr> <th rowspan="2">Frequency Range</th> <th colspan="2">Group 1, Class A Quasi-Peak Limit [dBuV/M]</th> </tr> <tr> <th>10.0 Meters</th> <th>3.0 Meters</th> </tr> </thead> <tbody> <tr> <td>30 to 230 MHz</td> <td>40</td> <td>50</td> </tr> <tr> <td>230 MHz to 1 GHz</td> <td>47</td> <td>57</td> </tr> </tbody> </table>	Frequency Range	Group 1, Class A Quasi-Peak Limit [dBuV/M]		10.0 Meters	3.0 Meters	30 to 230 MHz	40	50	230 MHz to 1 GHz	47	57																	
Frequency Range	Group 1, Class A Quasi-Peak Limit [dBuV/M]																													
	10.0 Meters	3.0 Meters																												
30 to 230 MHz	40	50																												
230 MHz to 1 GHz	47	57																												
Harmonic emissions IEC 61000-3-2	Complies	<table border="1"> <thead> <tr> <th>Harmonic Order N</th> <th>Maximum Permissible Harmonic Current A</th> </tr> </thead> <tbody> <tr> <td colspan="2" style="text-align: center;">Odd Harmonics</td> </tr> <tr> <td>3</td> <td>2.30</td> </tr> <tr> <td>5</td> <td>1.14</td> </tr> <tr> <td>7</td> <td>0.77</td> </tr> <tr> <td>9</td> <td>0.40</td> </tr> <tr> <td>11</td> <td>0.33</td> </tr> <tr> <td>13</td> <td>0.21</td> </tr> <tr> <td>15 ≤ n ≤ 39</td> <td>0.15 * (15/n)</td> </tr> <tr> <td colspan="2" style="text-align: center;">Even Harmonics</td> </tr> <tr> <td>2</td> <td>1.08</td> </tr> <tr> <td>4</td> <td>0.43</td> </tr> <tr> <td>6</td> <td>0.30</td> </tr> <tr> <td>8 ≤ n ≤ 40</td> <td>0.23 * (8/n)</td> </tr> </tbody> </table>	Harmonic Order N	Maximum Permissible Harmonic Current A	Odd Harmonics		3	2.30	5	1.14	7	0.77	9	0.40	11	0.33	13	0.21	15 ≤ n ≤ 39	0.15 * (15/n)	Even Harmonics		2	1.08	4	0.43	6	0.30	8 ≤ n ≤ 40	0.23 * (8/n)
Harmonic Order N	Maximum Permissible Harmonic Current A																													
Odd Harmonics																														
3	2.30																													
5	1.14																													
7	0.77																													
9	0.40																													
11	0.33																													
13	0.21																													
15 ≤ n ≤ 39	0.15 * (15/n)																													
Even Harmonics																														
2	1.08																													
4	0.43																													
6	0.30																													
8 ≤ n ≤ 40	0.23 * (8/n)																													
Voltage fluctuations/flicker emissions IEC 61000-3-3	Complies	<p>The limits shown below were used to determine compliance to the requirements of IEC 61000-3-3.</p> <ul style="list-style-type: none"> • The value of Pst shall not be greater than 1.0; • The value of Plt shall not be greater than 0.65; • The value of d(t) during a voltage change shall not exceed 3.3% for more than 500ms; • The relative steady-state voltage change, dc, shall not exceed 3.3%; • The maximum relative voltage change dmax shall not exceed: <ul style="list-style-type: none"> ○ 4% without additional conditions; ○ 6% for equipment which is: <ul style="list-style-type: none"> • Switched manually, or • Switched automatically more frequently than twice per day, and also has either a delayed restart (the delay being not less than a few tens of seconds), or manual restart, after a power supply interruption 																												

		<ul style="list-style-type: none"> ○ 7% for equipment which is; <ul style="list-style-type: none"> • Attended whilst in use (for example: hair dryers, vacuum cleaners, kitchen equipment such as mixers, garden equipment such as lawn mowers, portable tools such as electric drills), or • Switched on automatically, or is intended to be switched on manually, no more than twice per day, and also has either a delayed restart (the delay being not less than a few tens of seconds) or manual restart, after a power supply interruption <p>Pst and Pit requirements were not applied to voltage changes caused by manual switching.</p> <p>The limits were not applied to voltage changes associated with emergency switching or emergency interruptions.</p>						
Electrostatic Discharge IEC 61000-4-2	Complies	+/- 8.0 kV, contact +/- 2 kV, +/- 4 kV, +/- 8 kV, +/- 15 kV, Air						
Radiated Immunity IEC 61000-4-3	Complies	<table style="width: 100%; border: none;"> <tr> <td style="text-align: center;">3 V/m</td> <td style="text-align: center;">3 V/m</td> </tr> <tr> <td style="text-align: center;">80 to 1000 MHz</td> <td style="text-align: center;">1.0 to 2.7 GHz</td> </tr> <tr> <td colspan="2" style="text-align: center;">80 % AM at 1kHz</td> </tr> </table>	3 V/m	3 V/m	80 to 1000 MHz	1.0 to 2.7 GHz	80 % AM at 1kHz	
3 V/m	3 V/m							
80 to 1000 MHz	1.0 to 2.7 GHz							
80 % AM at 1kHz								
Electrical Fast Transient/Burst, Power Ports, I/O Ports IEC 61000-4-4	Complies	Power Ports: +/- 0.5 kV, +/- 1.0 kV, +/- 2.0 kV IO Ports: +/- 0.25 kV, +/- 0.5 kV, +/- 1.0 kV 100 Hz repetition frequency						
Surge Immunity IEC 61000-4-5	Complies	+/- 0.5 kV, +/- 1.0 kV Differential Mode +/- 0.5 kV, +/- 1.0 kV, +/- 2.0 kV Common Mode						
Conducted Immunity Power Ports, I/O Ports IEC 61000-4-6	Complies	Power Ports: 3 Vrms 0.15 to 80 MHz 6 Vrms in ISM test bands: 6.765 to 6.795, 13.553 to 13.567, 26.957 to 27.283, 40.660 to 40.700 MHz 1 kHz, 80%, AM IO Ports: 3 Vrms 0.15 to 80 MHz 1 kHz, 80%, AM						
Magnetic Immunity IEC 61000-4-8	Complies	30 A/M RMS 50 Hz						
Voltage Dips, Interrupts and Variations IEC 61000-4-11	Complies	0 % Ut 0.5 cycle (Variations) At 0°, 45°, 90°, 135°, 180°, 225°, 270°, and 315°						
		0 %t, 1 cycle (Variations) And 70 % Ut, 25 cycles Single Phase at 0°						
		0 % Ut, 250 cycles (Interrupts)						

1.6 COMPLIANCE NOTICE

The Source-Ray PXS-710D you have purchased has been designed, manufactured, and calibrated to comply with the governing Federal Regulations 21 CFR Subchapter J. The maintenance schedules included are crucial to the continued reliability of this equipment with respect to regulatory compliance.

CLASS I – INTERMITTENT MODE**PXS-710D SOURCE CONSISTING OF:**

- X-Ray Generator/ Tube Housing (PXS-710D-G)
- Base Assembly
- Remote Control Module (Optional)

INDICATION FOR USE:

The model PXS-710D Podiatry X-Ray source is intended for General Purpose Radiographic exams utilizing film, computed radiography, or direct digital flat panels. Not for mammographic use. Rx Only. Imaging Equipment is Provided/Integrated by the end User.

SPECIFIED RANGE OF COMPLIANCE:

Tube Current: 10 mA

Tube Voltage: 40 - 70 kVp

Milliamperere-second: 0.1 – 20 mAs

1.7 SAFETY STANDARDS

The Source-Ray PXS-710D you have purchased has been designed, manufactured, and calibrated to meet the following safety standards;

- Podiatry X-ray source with radiation protection in accordance with IEC 60601-1-3:2008.
- Podiatry X-ray source for radiography in accordance with IEC 60601-2-54:2009.
- X-ray tube assembly in accordance with IEC 60601-2-28:2010.

1.8 ELECTRICAL SPECIFICATIONS**MILLIAMPERES**

Milliamperes will not deviate from the selected value by more than $\pm 5\%$ within the operating line voltage range and within the specified range of line voltage regulation.

KILOVOLTS

Kilovoltage will not deviate from the selected value by more than $\pm 5\%$ of full scale

MAS

MAS will not deviate from the selected value more than $\pm 8\%$ or 0.2 mAs whichever is greater within a range of 0.10 – 20 mAs.

MAXIMUM RATING

10 mA at 70 kVp DC

kVp Range	Max Time	mA	Max mAs
40 –70	2.00 Sec.	10.0	20.0

LINE VOLTAGE REGULATION

5% maximum as measured at the x-ray control panel at maximum rated output.

INPUT ELECTRICAL RATING

➤ For 115V Installation:

- Line Voltage Range: 115VAC, 60 Hz
- Momentary Max Line Current: 13 A, @ 70kVp and 10mA
- Long Term Max Line Current: 2 A, @ Standby
- Mains Resistance: Measured at the line input connector, not to exceed 0.88Ω

1.8 CONTINUED:NOMINAL ELECTRIC POWER

700 W, Constant potential derived from a high frequency inverter source, Regulated for both kVp and mA.

MAX OUTPUT POWER

Instantaneous: 700W (70kV @ 10 mA)

DUTY CYCLE (AUTOMATIC)

3.3% (ie.. X-ray Exposure 1 second ON, 30 seconds OFF)

MINIMUM PERMANENT FILTRATION

1.8 mm of aluminum equivalent at 70 kVp

REFERENCE CURRENT TIME PRODUCT (Power On Defaults)

Beam Current: 10 mA

Tube Potential: 60 kVp

mAs Setting: 1.60 mAs

LEAKAGE TECHNIQUE FACTORS

Testing is performed at 70 kVp and 10 mA, 10 mAs exposure.

COOLING CURVES

Automatic inhibit circuits provide a delay between exposures proportional to the exposure time. This delay is sufficient to allow proper tube cooling. The delay between exposures varies between 2 seconds and 60 seconds depending on the exposure time.

1.8 CONTINUED:

ENVIRONMENTAL

➤ OPERATING:

- Temperature: 40°F - 90°F (5°C - 32°C)
- Pressure: 70 kPa – 106 kPa
- Humidity: 30% - 90% (Non-Condensing)

➤ STORAGE:

- Temperature: 30°F - 110°F (-1°C - 43°C)
- Pressure: 70 kPa – 106 kPa
- Humidity: 30% - 90% (Non-Condensing)

1.9 X-RAY TUBE CHARACTERISTICS

X-RAY TUBE TYPE

Superior SXR-90-15-0.5

ENVELOPE

Hard glass, Borosilicate 0.085 thick.

ANODE MATERIAL

Tungsten target, copper plated and vacuum cast in copper.

TARGET ANGLE

15 Degree

FOCAL SPOT

0.5 mm nominal as per N.E.M.A. XR-5.

CATHODE

Tungsten filament, line focus.

1.9 CONTINUED:

INHERENT FILTRATION

Minimum 0.65 mm aluminum equivalent at 80 kVp

COOLING

Natural convection through the insulating medium to the enclosure

INSULATING MEDIUM

Highly refined transformer oil; breakdown dielectric strength of not less than 45 kVp per ASTM

D 877-49

WEIGHT

13.5 ounces (384 grams) approximately

X-RAY TUBE SHIELDING

Approximate equivalent to 0.062 of lead for scatter radiation.

This X-ray unit maybe dangerous to patient and operator unless safe exposure factors, operating instructions and maintenance schedules are observed.

MAXIMUM VOLTAGE

90 kVp

MAXIMUM ENERGY

1.4 mA continuous at 90 kVp in cooled oil. Maximum temperature <70° centigrade.

MAXIMUM TUBE POWER

1.8 kW

1.9 CONTINUED:

THERMAL

Oil insulation

ANODE HEAT STORAGE

25,000 Heat Units

ANODE COOLING RATE

200 Heat Units / sec.

NOTE: Heat Unit = kVp x mAs

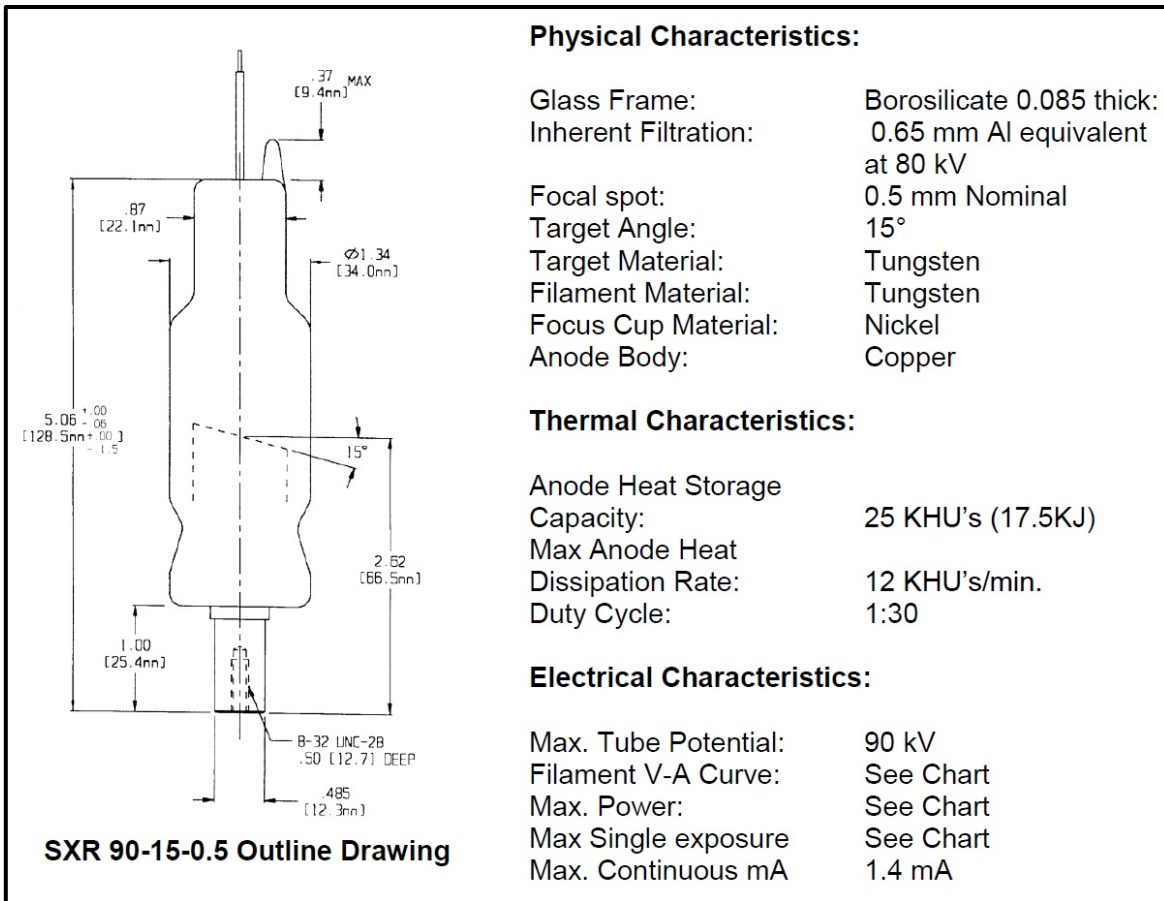
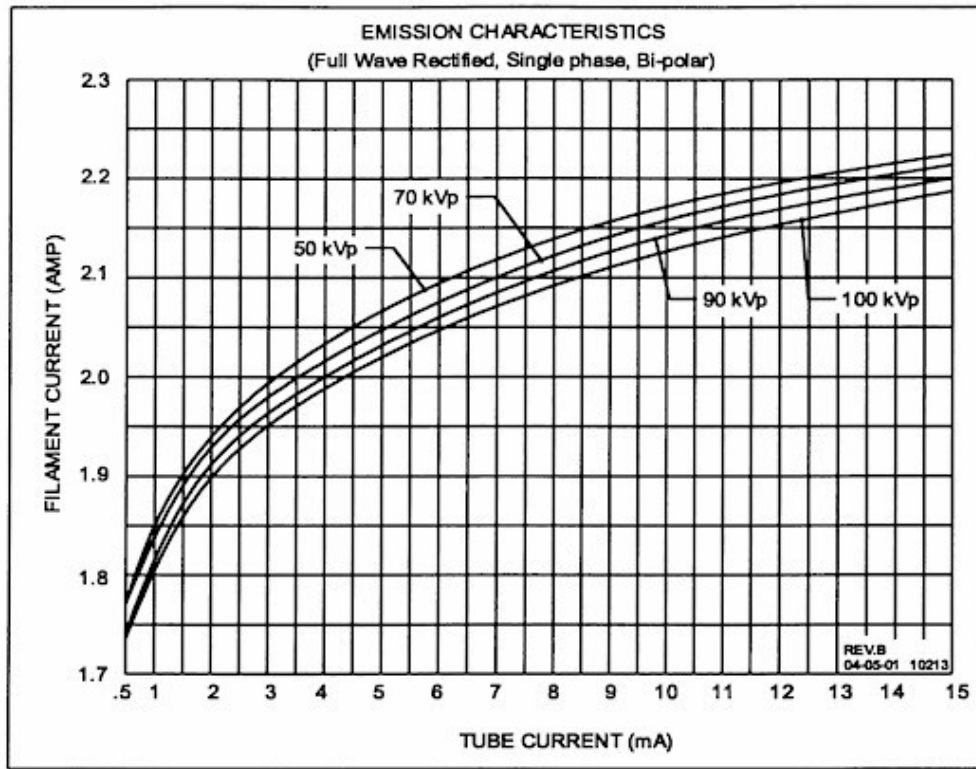
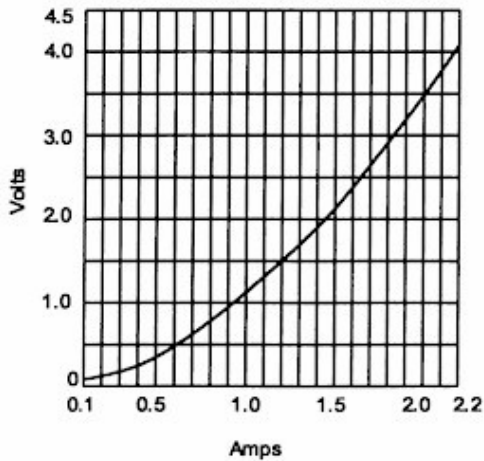


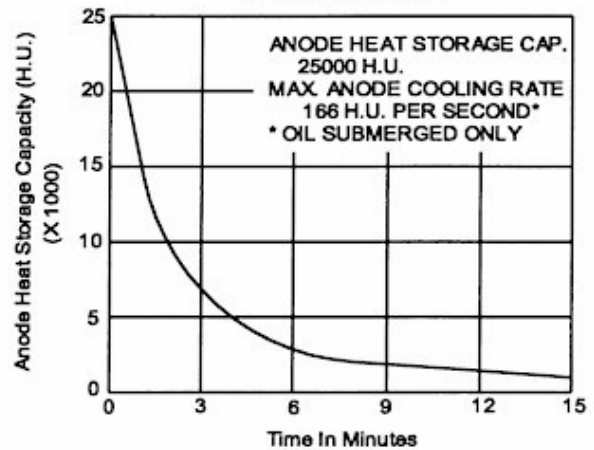
FIGURE 1.1
X-RAY TUBE CHARACTERISTICS



Filament Volt/Amps Characteristics:
60 Hz AC & DC



Anode Cooling Curve



H.U. (Heat Units) = kVp (Kilovolts Peak) x mA (rms) x Time (sec.)
Joules = .707 x H.U.

SUPERIOR X-RAY TUBE CO.
REV. A 07-08-04

SXR-90-15 & SXR-90-15M2
0.5 FOCAL SPOT

FIGURE 1.2
X-RAY TUBE RATING CHARTS

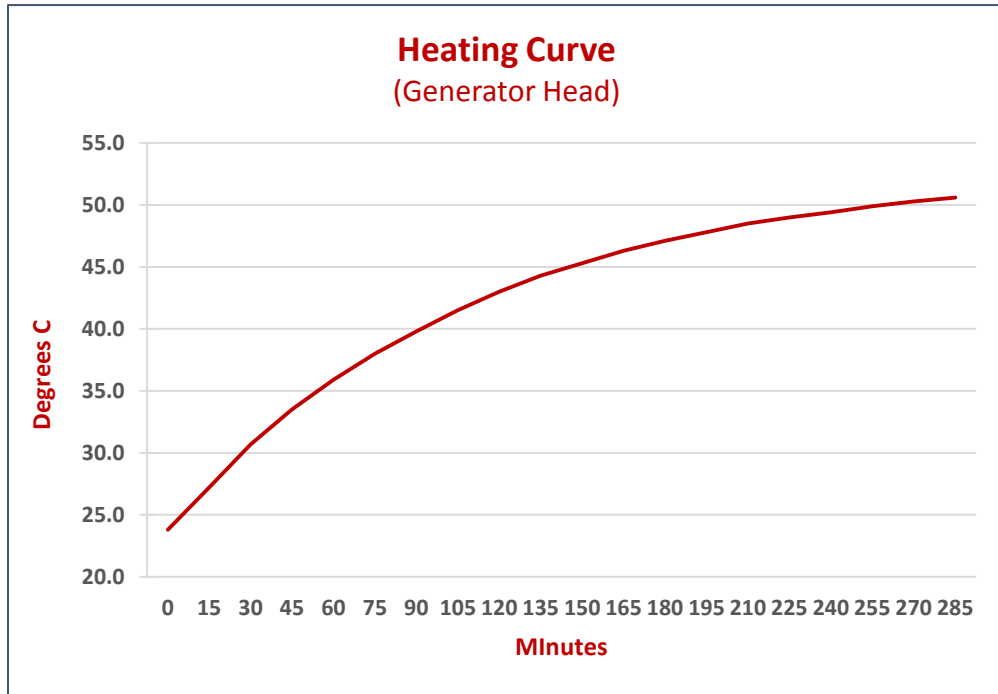


FIGURE 1.3
X-RAY HEAD HEATING CHART

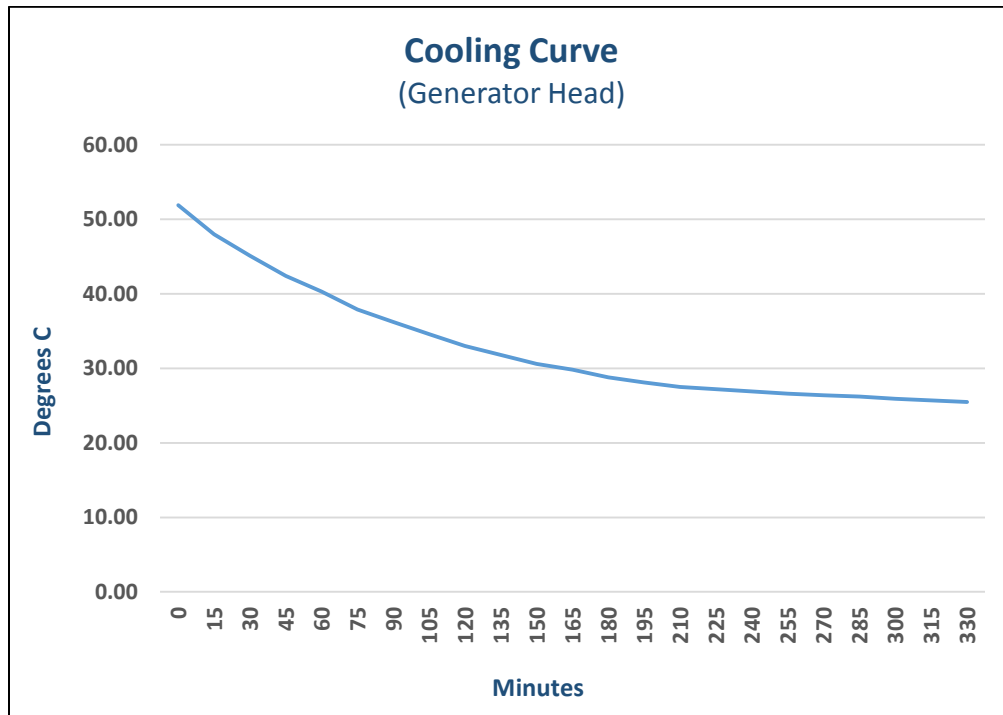


FIGURE 1.4
X-RAY HEAD COOLING CHART

1.10 X-RAY COLLIMATOR:

Model: Collimare R72S

Rating: 80 kVp

LED Crosshairs (Center locator)

Light Field (LED, 12VDC @ 2A, 24VDC @ 1A or 24VAC @ 1A)

COMPLIES WITH DHHS RADIATION STANDARD 21 CFR SUBCHAPTER J

Conforms to ANSI/AAMI ES60601-1

Certified to CSA STD C22.2 No.60601-1

1.11 MECHANICAL SPECIFICATION:

X-RAY GENERATOR ASSEMBLY:

<u>PHYSICAL SIZE:</u>	<u>LENGTH</u>	<u>WIDTH</u>	<u>HEIGHT</u>
	12.6 in.	10.1 in.	13.2 in.
	32 cm	25.7 cm	33.5 cm

GROSS WEIGHT: 29 lb., 13.1 KG

X-RAY SOURCE:

PHYSICAL SIZE: Reference figure 1.5

GROSS WEIGHT: 113 lb., 51.2 KG

PODIATRY BASE PLATFORM WEIGHT CAPACITY: 300 lb., 136 KG

AL EQUIVALENCE: Foot Plate Material: Less than 1.2mm AL

REMOTE CONTROL MODULE SR-115-RC (OPTIONAL):

<u>PHYSICAL SIZE:</u>	<u>LENGTH</u>	<u>WIDTH</u>	<u>HEIGHT</u>
	7.30 in.	3.30 in.	1.14 in.

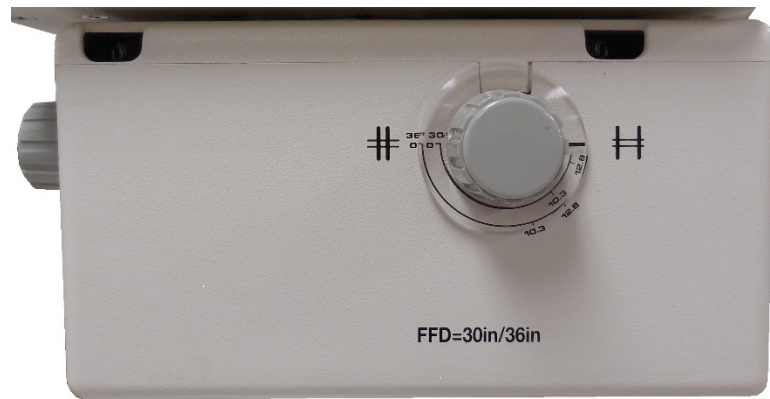


FIGURE 1.5
COLLIMATOR FRONT VIEW

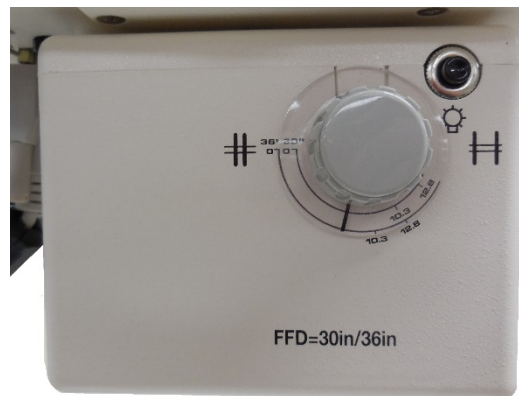


FIGURE 1.6
COLLIMATOR SIDE VIEW

1.12 EQUIPMENT CLASSIFICATION:

- Protection against electric shock: Class I with no applied parts.
- Protection against ingress of fluids: No protection against ingress of fluids (IPX0).
- Not suitable for use in oxygen rich environment.
- Mode of Operation: Non-continuous operation.
- Overvoltage Category: Overvoltage category II.
- Rated Altitude: 2000 meters

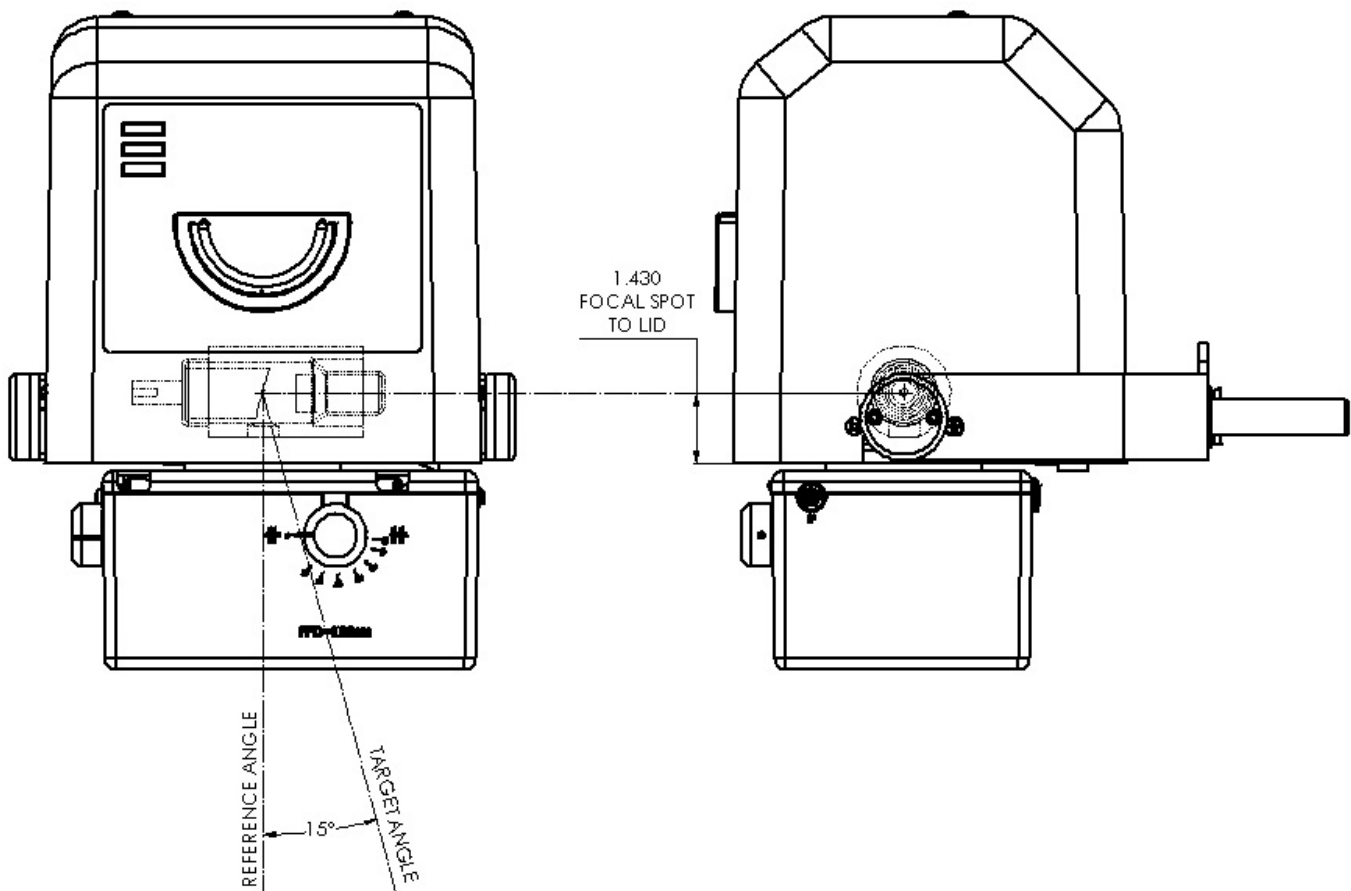


FIGURE 1.7
FOCAL SPOT LOCATION (GENERATOR ASSEMBLY)

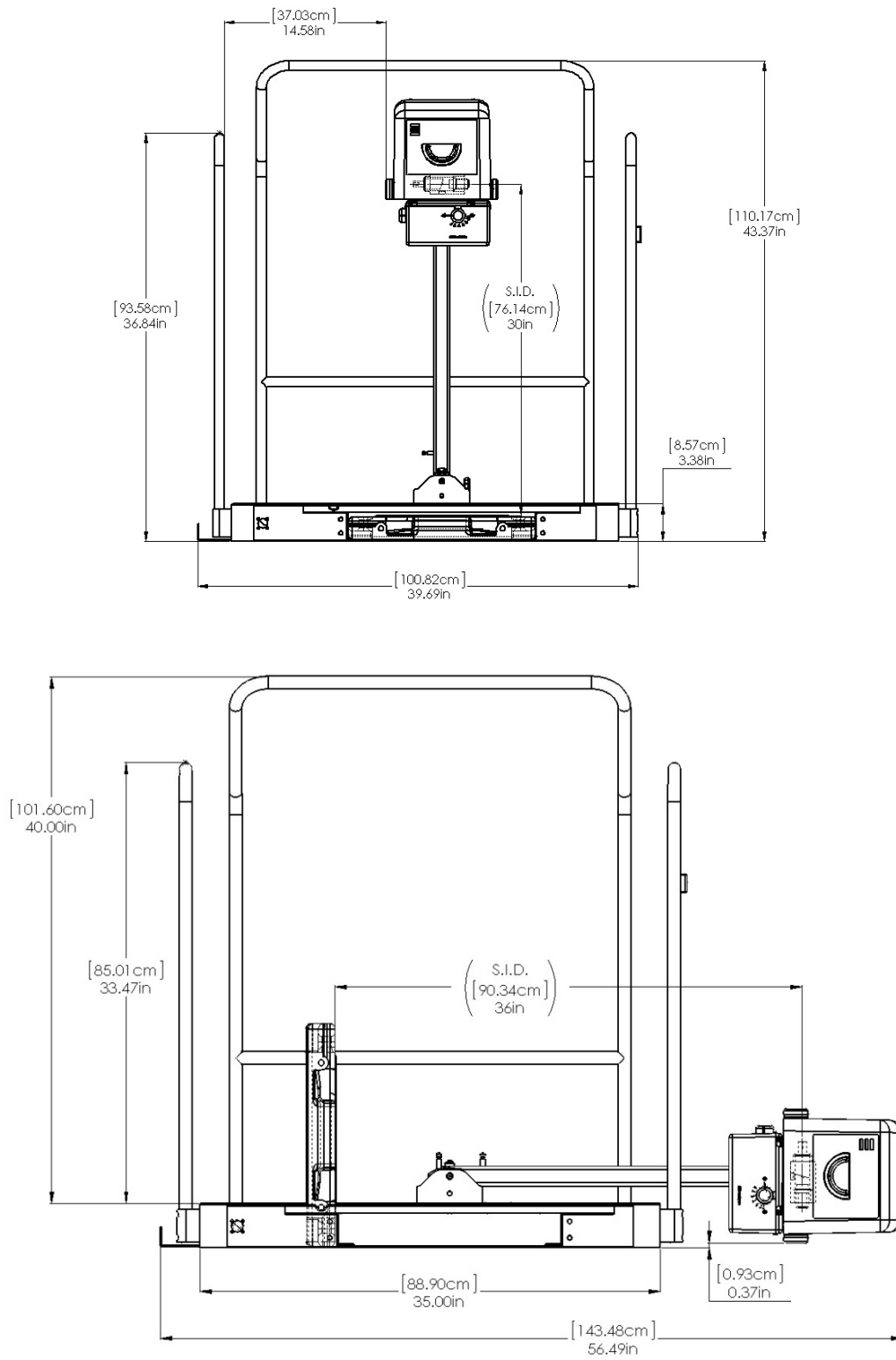


FIGURE 1.8
SOURCE DIMENSIONS

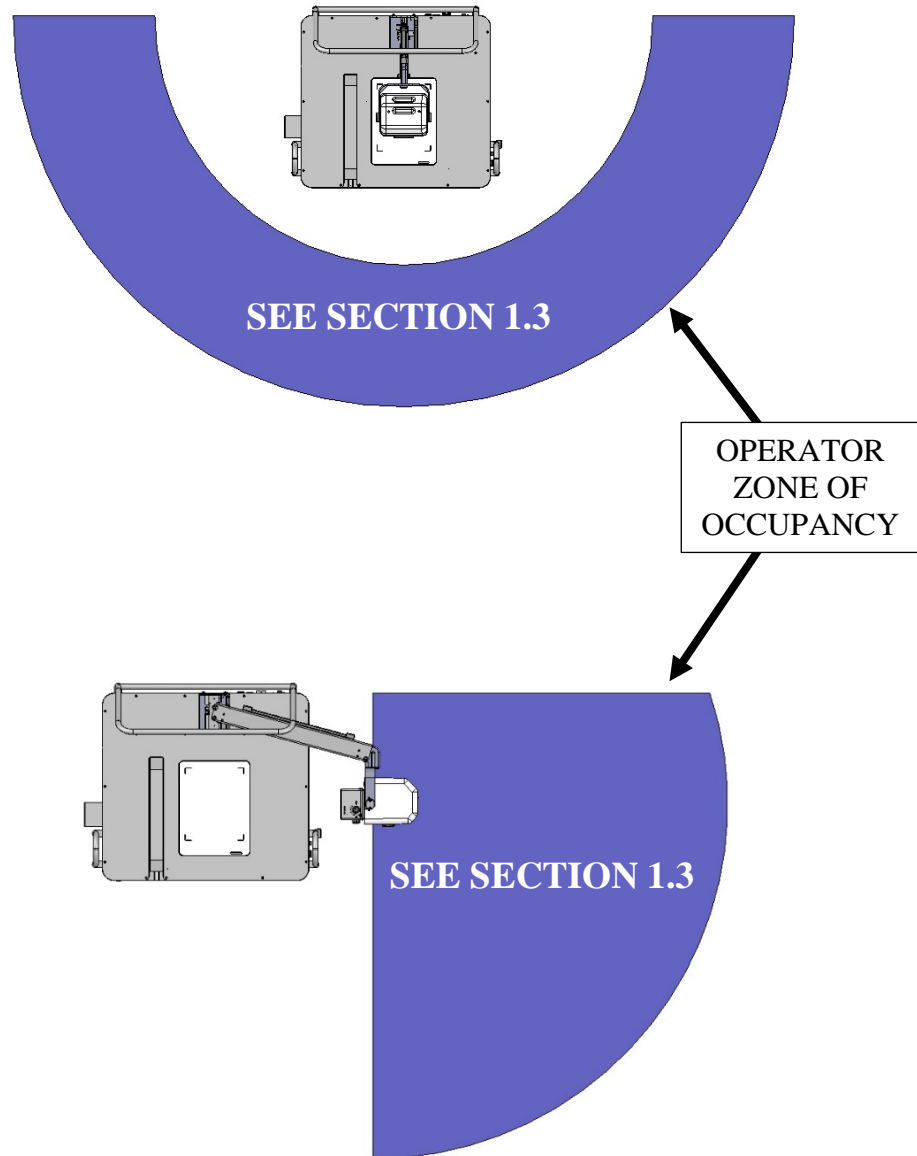


FIGURE 1.9
ZONE OF OCCUPANCY

INSTALLATION AND CALIBRATION

CAUTION



This Section Pertains To Authorized Source-Ray Service Personnel Only

The Podiatry Support Base contains a spring-loaded arm with 500 pounds of force.

Never move the arm without the X-Ray head attached.

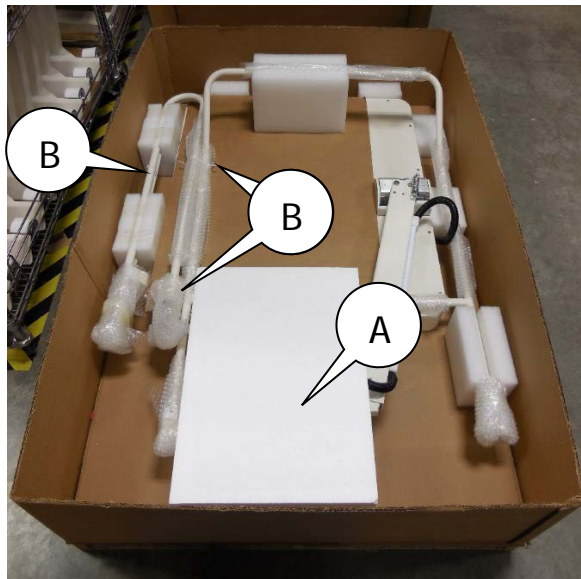
Never remove the X-ray Head while the arm is in a position other than 90° (Vertical)

Equipment installation and servicing procedures should be performed by properly
trained and qualified service personal only.

Do not operate the unit if water has leaked into or around the unit base. Call service
before applying power to the source.

2.1 UN-PACKAGING

Remove the top carton to expose the below contents;

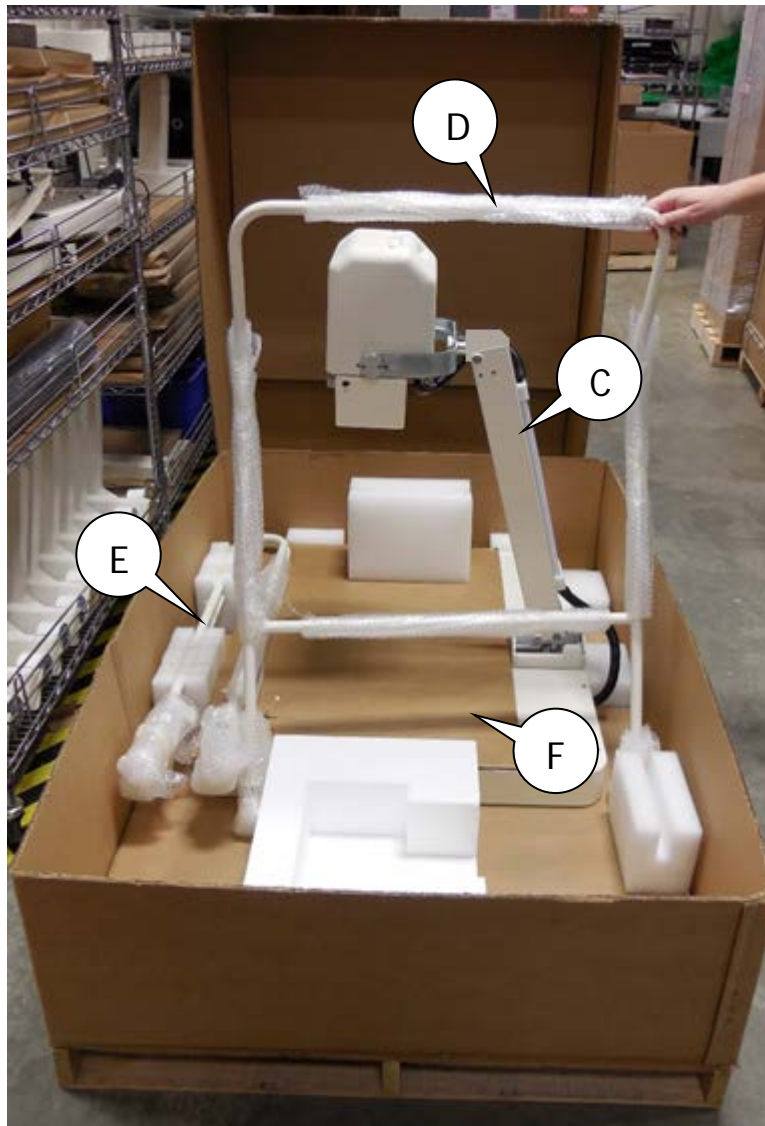


2.1 CONTINUED:

- 2) Remove the top polystyrene cushion (A), which secures the generator, and put aside.
- 3) Cut off the 3 cable ties located on the Patient Handrails (B).

WARNING: *The Podiatry Support Base contains a spring-loaded arm with 500 pounds of force.*

- 4) Lift the Arm (C) up 90° and remove the Patient Back Handrail (D) and put aside.



- 5) Remove the Patient Side Handrails (E) from the cushions and put aside.
- 6) Remove the back handrail cushion from the box.
- 7) Remove the Podiatry Source (Model PXS-710D) from the box and put aside.

2.2 ASSEMBLY (REFERENCE FIGURE 2.1 & 2.2)

- 1) Secure the Patient Side Handrails (A) to the left and right side of the Podiatry Base (B) from the outside using 4 ea. 1/4-20 x 2" SHCS (E). Tighten securely.
- 2) Secure the Patient Back Handrail (C) to the backside of the Podiatry Base (B) from the outside using 4 ea. 1/4-20 x 2" SHCS. Tighten securely.
- 3) Place the Podiatry Support Base (B) in its final location.
- 4) Remove the Base Plate and anchor the unit to the floor using the base mounting holes (D) & appropriate fasteners for the substrate. Re-attach Base Plate once anchored.

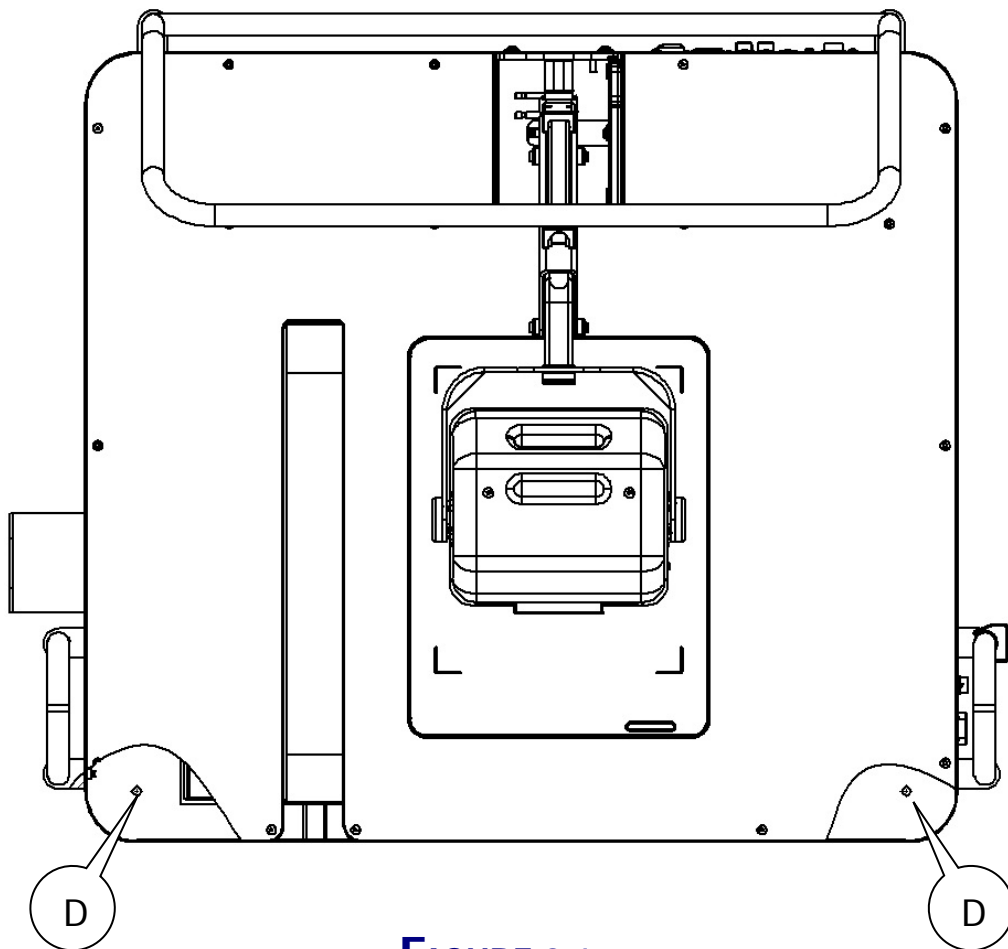


FIGURE 2.1
ANCHOR POINTS

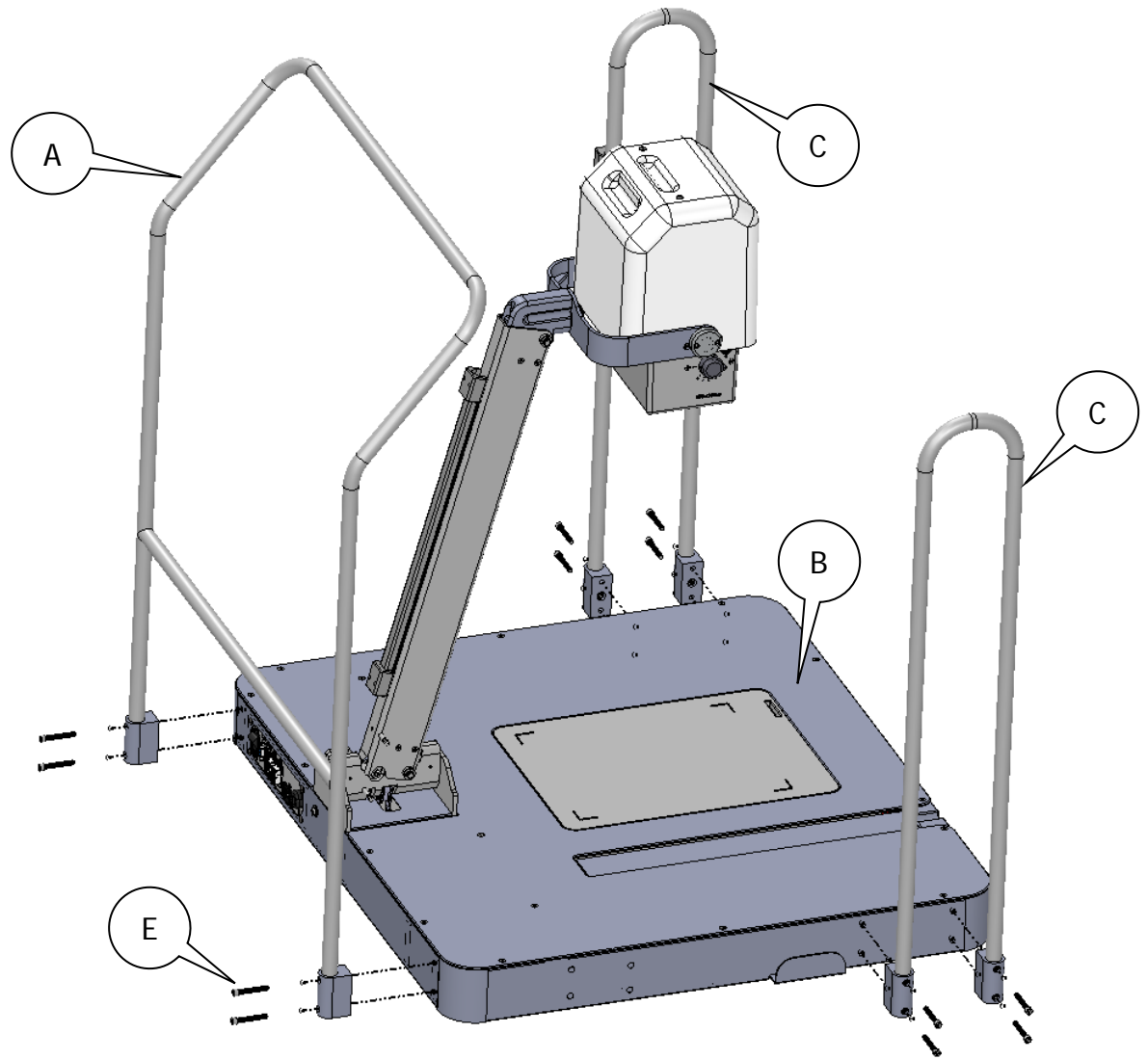


FIGURE 2.2
HANDRAIL ASSEMBLY

CAUTION

Be certain that the primary power source (wall outlet) is the same rating as the voltage specified on the label, located on the rear panel of the x-ray control.

The power cord acts as mains disconnect device.

2.3 ELECTRICAL CONNECTIONS

Be certain that the primary power source (wall outlet) is the same rating as the voltage specified on the label, located on the underside of the Generator Assembly.

Connect the following connections at the Control/Generator Assembly. The Base Cable Assembly attached to the Boom Arm Assembly provides connection to the Source Base assembly (Reference Figures 3.1, 3.5, & 3.6):

- 1) Connect the power cord from the Base cable assembly to the power Inlet (2).
- 2) Connect the Remote Control Interface cable from the Base cable assembly to the Interface connector (5).
- 3) Connect the Exposure Switch from the Base cable assembly to the Exposure connector (3). Connect the RS-232 Cable from the Base cable assembly to the RS-232 interface connector. (6) Connect the Following Source Base connections.
- 4) Connect the power cord from the Base cable assembly to the power Inlet (D).
- 5) Optional, Connect the Remote Control Interface cable from the Base cable assembly to the Interface connector (B).
- 6) Connect the Exposure Switch & the accessibility Bracket from the Base cable assembly to the Exposure connector by reusing supplied hardware (O).
- 7) Connect the RS-232 Cable from the Base cable assembly to the RS-232 interface connector. (A)

2.4 CALIBRATION SET-UP

- Connect the mAs meter to the phone jack (J3) located on the top back plate of the Control/Generator Assy. Place the kVp meter (Unfors model 514L) in the X-Ray field @ 30" SID, and run calibration procedure.
- Connect an Oscilloscope to TP7 and TP8 (GND) on the Control Board 950132.

2.5 TUBE POTENTIAL (kVp) and Beam Current (mA)**2.5.1 MICRO-CONTROLLER OPERATIONAL MODES:**

- Manual Operation Mode
- Calibration Mode

2.5.2 MANUAL OPERATION

This is the default mode of operation, which normally appears immediately after the Power On Self Test (POST).

- To adjust kV output, use the kV Up and kV Down keys.
- To select mAs setting, use the mAs Up and mAs Down Keys.

2.5.3 CALIBRATION MODE (W/OPTIONAL SR-115-RC)

To enter the Calibration Mode, Connect the Remote Control SR-115-RC. Turn the unit ON and press "*kV Up*", "*Reset*", and "*mAs Up*" simultaneously and hold for approximately 10 seconds during the POST condition. The display will show 710, wait for the 'Chirp' and then release the keys.

Successful entrance into the calibration mode will result in the following displays - kVp: "710", mAs: "1.00" (or whatever the current firmware version is e.g.; "2.10"). Hold "*kV Up*", "*Reset*", and "*mAs Up*" for approximately 4 seconds to enter the calibration mode.

2.5.3 CONTINUED:

There are eight Calibration adjustments:

40kVp Preheat, kVp

50kVp Preheat, kVp

60kVp Preheat, kVp

70kVp Preheat, kVp

The displays will then change to; kVp: "04", mAs: "0 – 255", indicating that the source is ready to calibrate the 40kVp Preheat setting.

- 1) Make an exposure and measure the actual mA waveform on the Oscilloscope.
- 2) To increase or decrease the Preheat, Press kV up or down. Each activation of the button increases or decreases the Preheat. The number displayed in the mAs window represents a digital code for Preheat reference and is increased or decreased by one with each activation of the kV switches. Adjust the Preheat until the mA waveform is square with as little overshoot or undershoot as possible.
- 3) When the calibration is completed for the 40 kVp Preheat range, depress the "**RESET**" to move to the kVp adjustment. The display will show 05.
- 4) Place a Non-invasive kVp detector in the X-Ray Beam.
- 5) Make an exposure and measure the actual kVp.

2.5.3 CONTINUED:

- 6) To increase or decrease the kVp, Press kV up or down. Each activation of the button increases or decreases the kVp approximately 05. kVp. The number displayed in the mAs window represents a digital code for kVp reference and is increased or decreased by one with each activation of the kV switches. Adjust the kVp until the Actual kVp is within specifications.
- 7) When the calibration of kVp is completed for the 40 kVp range, press the "**RESET**" to move to the adjustment.
- 8) Repeat steps 1 – 7 for the 50, 60 and 70 kVp ranges. The Display will show 04,05,06,07 for the Preheat adjustments and 40,50,60,70 for the kVp adjustments.
- 9) Press RESET until the kVp Display shows '60'.
- 10) Reset the MAS Meter to Zero.
- 11) Make an Exposure and measure the actual mAs.
- 12) Observe the reading on the MAS meter. The reading should be 1.0mAs +/- 5%. If adjustment is required, adjust R102 on the Control board assembly. Inspect squareness of wave-shape and repeat steps b - h above if necessary.
- 13) When calibration is complete Recycle power to the unit to return to normal operation mode.

2.5.4 CALIBRATION MODE (W/PXS-710D CALIBRATION UTILITY)

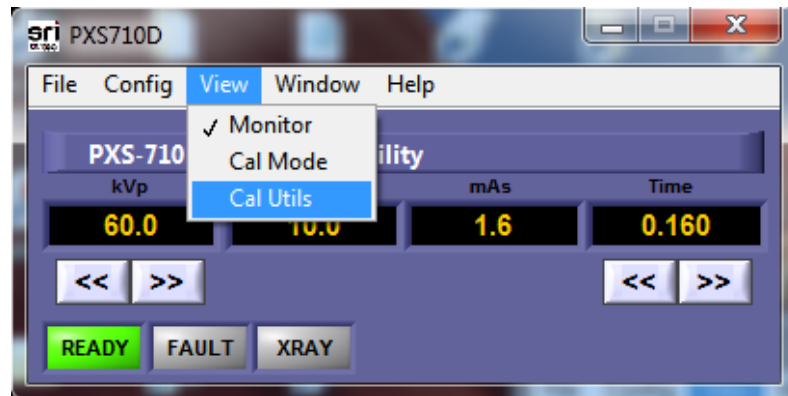
The PXS-710D Calibration Utility allows calibration of the PXS-710D with a host computer connected to the Serial RS-232 Port of the Generator.

The PXS-710D Calibration Utility CD-ROM is provided with this documentation.

Run the installation program and install the Utility.

The Default Serial COM port is COM1, be sure to configure the Host PC accordingly.

- a. Start the PXS710D utility, PXS710D.exe . Located in the following directory: C:\Program Files\PXS-710D\
- b. From the Drop-down menu select "**Cal Utils**" as shown in Fig. 2.3



**Figure 2.3
View Menu**

- c. The Calibration Menu is password protected. In the password Dialog enter "**yarx**". (Fig. 2.4)

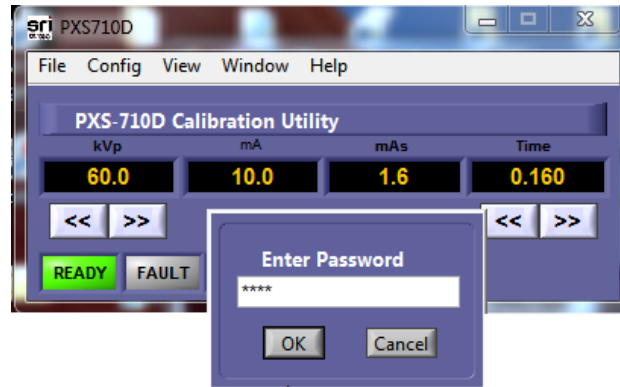
2.5.4 CONTINUED:

Figure 2.4
Password Dialog Box

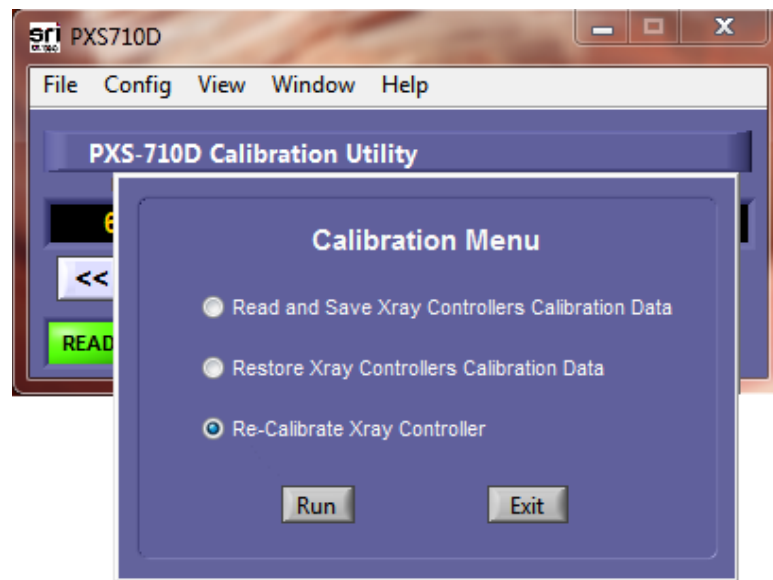


Figure 2.5
Calibration Menu

- d. Select "**Re-Calibrate XRay Controller**" from the Calibration Menu. Click '**Run**' to enter the Calibration wizard. Ref Fig. 2.5
- e. The Calibration Displays the Current Calibration point, kVp, mA and Time. Ref. Fig. 2.6

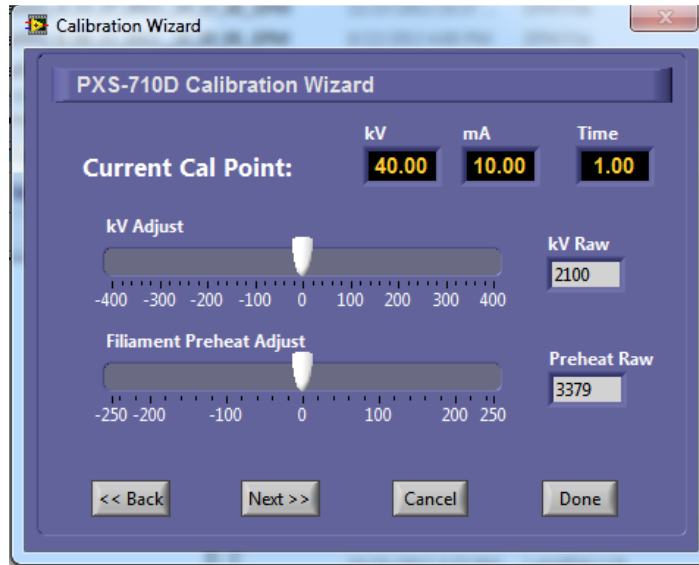
2.5.4 CONTINUED:

Figure 2.6
Calibration Wizard

- f. Make an exposure and measure the actual mA waveform on the Oscilloscope.
- g. To increase or decrease the Preheat, use the '**Filament Preheat adjust**' slider to adjust Preheat up or down. The number displayed in the Preheat Raw window represents a digital code for Preheat reference and is increased or decreased by the slider control. Adjust the Preheat until the mA waveform is square with as little overshoot or undershoot as possible.
- h. Make an Exposure and verify the actual mA waveform on the Oscilloscope, Repeat step g if more adjustment is required.
- i. To increase or decrease the kVp, use the '**kV adjust slider**' to adjust kV up or down. The number displayed in the kV Raw window represents a digital code for kVp reference and is increased or decreased by the slider control. Adjust the kVp until the Actual kVp is within specifications.

2.5.4 CONTINUED:

- j. Make an Exposure and verify the actual kVp value, Repeat step i if more adjustment is required.
- k. Using the attached mAs meter, measure the mAs for the 1 sec. exposure. Verify that the reading is 10.0 mAs (1.0 mAs +/- 5%). If adjustment is required, adjust R102 on the Control board assembly P/N 950132. Inspect squareness of wave-shape and repeat steps f - g above if necessary.
- l. When the calibration is completed for the 40 kVp preheat range, depress the "**NEXT**" button to move to the next calibration station. Repeat steps f – k. This process is repeated for 50, 60, and 70 kVp, as displayed in the kV window.
- m. Once the 70 kVp station is calibrated, pressing "**NEXT**" results in a confirmation dialog as in fig 2.7. Click on the '**OK**' button to proceed.

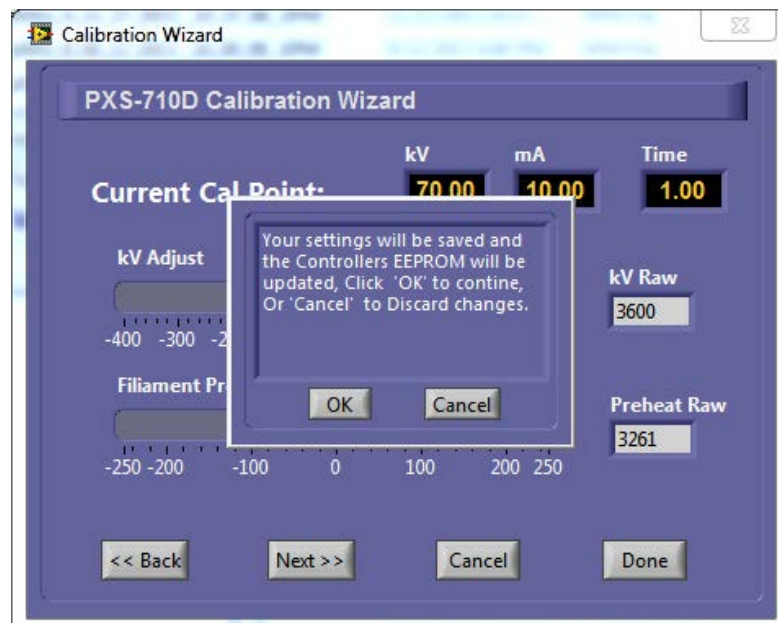


Figure 2.7
Settings Confirmation

2.5.4 CONTINUED:

- n. Once the new calibration settings are saved, a confirmation dialog is displayed. Click on 'OK' to proceed, you will be returned back to the "Calibration Menu". Ref fig 2.8

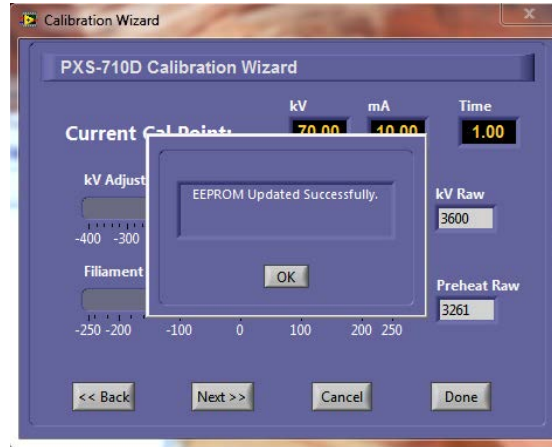


Figure 2.8
Settings Saved Confirmation

- o. Exit the 'Calibration Menu' by clicking 'EXIT'. Ref fig 2.9
- p. Exit the PXS710D.exe Calibration Utility by selecting 'File->Exit' from the drop down menu.

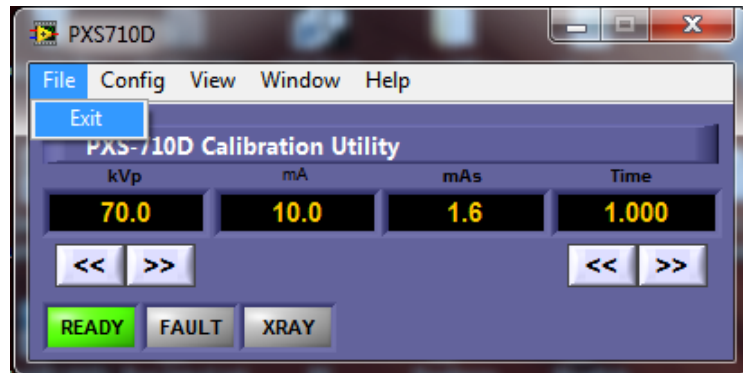


Figure 2.9
Application Exit

2.5.5 NORMAL OPERATION (W/PXS-710D CALIBRATION UTILITY)

The PXS-710D Calibration Utility can be used as a standalone controller for the PXS-710D allowing setting kVp, mAs and manual Exposure control.

- a. Start the PXS710D Utility, PXS710DCal.exe located in the following directory: C:\Program Files\PXS-710D\
- b. From the Drop-down menu select, "**Cal Mode**" as shown in fig. 2.10 below.

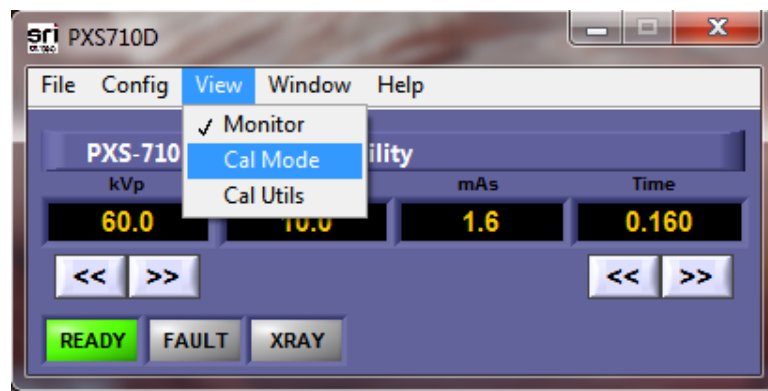


Figure 2.10
Calibration Mode Selection

- c. Calibration Mode adds additional diagnostic information to the application window. Ref fig. 2.11. This information is shown once the **PREP** switch on the Exposure switch is depressed.
 - 1) Firmware revision
 - 2) Controller state
 - 3) Firmware CRC

2.5.5 CONTINUED:

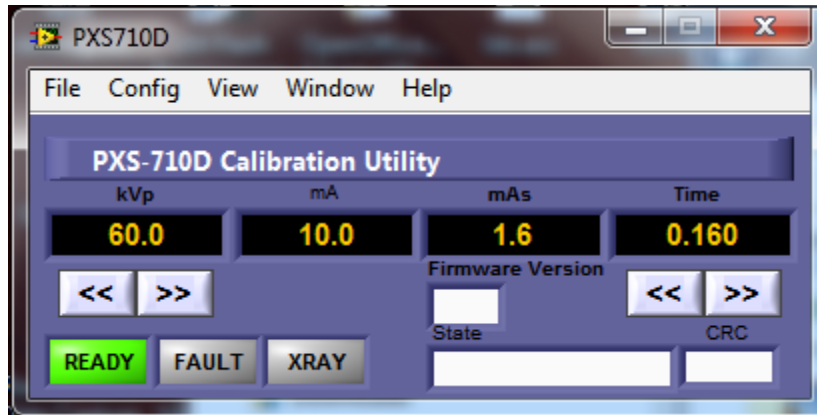


Figure 2.11
Calibration Mode UTILITY

- d. kVp adjustment is accomplished by the **UP** and **DOWN** buttons located under the kVp display.
- e. Time/mAs adjustment is accomplished by the **UP** and **DOWN** buttons located under the Time Display.
- f. To Prepare the Generator, press the Exposure switch's **PREP** button. A 2 second PREP display will be shown and turn **GREEN** when the unit is ready to Expose. Ref Fig. 2.12

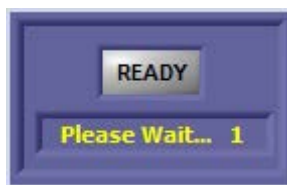


Figure 2.12
Ready Indicator

2.5.5 CONTINUED:

- g. To Make an X-Ray Exposure in the Cal Mode, press the **EXPOSE** button on the Exposure switch. Hold for the length of the exposure. Once the Exposure ends, release both the **PREP** and **EXPOSE** buttons on the Exposure switch.

An Exposure indicator will be displayed for the duration of the exposure. Ref fig 2.13. A XRAY indicator is present on the main application window as well.



Figure 2.13
X-ray Indicator

- h. When the 'Cal Mode' is no longer required, Select '**File->Exit**' from the drop down menu.

2.6 mas

Measure the mAs using the mAs meter and confirm accuracy as indicated on checklist.

2.7 BEAM ALIGNMENT

Tighten yoke block to prevent movement during alignment. Rotate Collimator so that the knobs are facing front and tighten lock. Remove the collimator outer shroud by removing the 4 screws securing the shroud to the collimator. Place the phosphor screen in the beam at 30.6" and collimate field just to the outside edge of the middle 5" x 7" rectangle. Place Beam Alignment Tool in center of field (center dot at intersection of centerlines) and adjust beam so that shadow of upper dot covers lower dot. Readjust borders if necessary.

Set the Control Module to 70kV, 20.0 mAs. Take an exposure while observing the X-Ray field through the lead glass window of the test cabinet. Note the difference observed between the light field and the X-Ray field for further adjustment.

If the centers are too far out of alignment, adjustment of Collimator light field is necessary. To adjust the horizontal position of the light field, rotate the unit 180 degrees to gain access to the mirror adjustment hardware. Loosen the locking screws sufficiently so as to allow the turning of the adjuster cam. Lock the fixing screw and cam after adjusting the mirror position. To adjust the vertical position of the light field, remove the lamp heat dissipater taking care to avoid being burned, as the dissipater can be very hot. Loosen the two lamp support fixing screws and using the hexagonal screw on the side of the lamp, adjust the lamp in the desired direction. Tighten the four screws fixing the lamp support.

Finally, to adjust the brightness at the edges of the light field, loosen the screws fixing the screen to the lamp holder, and using an Allen screws, move the screen to obtain the desired adjustment. Tighten the screen fixing screws.

UNIT OPERATION

3.1 CONTROLS AND INDICATORS (CONTROL PANEL)

<u>DESCRIPTION</u>	<u>FUNCTION</u>
1) GENERATOR POWER SWITCH	Power Switch for the Generator. See Section 3.2 (Item H) for the Digital Imaging Panel Power Switch.
2) A.C. INPUT CONNECTOR	Connects Control/Generator Assembly to supply mains.
3) EXPOSURE SWITCH CONN	Connects the exposure switch to the Control/Generator assembly.
4) MA TEST JACK	Test point for mA during the calibration mode.
5) CONTROL CONNECTOR	Connects the optional wall mount control module.
6) RS-232 CONNECTOR	RS-232 communications for remote host control via OpalRad or other control program. Note: See requirements for responsible organizations in section 1.4 of this manual.
7) KVP METER	A digital LED meter that indicates the kVp prior to exposure.
8) MAS METER	A digital LED meter that indicates the computed MAS prior to exposure.
9) KVP ADJUST	Two momentary switches that adjust the kVp from 40 to 80 kVp in 1 kVp increments.
10) MAS ADJUST	Two momentary switches that adjust the MAS up or down from 0.1 to 30 mAs.
11) READY INDICATOR	Color GREEN per 60601-1 3 rd Ed. Illuminates when unit is ready for operation. Automatically prevents excessive operation by means of a time delay circuit.

3.1 CONTINUED:

- | | |
|------------------------|--|
| 12) X-RAY ON INDICATOR | Color YELLOW per 60601-1 3 rd Ed. Illuminates when exposure switch is depressed to indicate that x-ray's are being produced for the pre-set time interval. In addition, an audio tone is generated at the same time. |
| 13) FAULT INDICATOR | Color RED per 60601-1 3 rd Ed. A lamp that illuminates to indicate that a fault condition has occurred. Refer to table 5.2 for a description of fault conditions. |
| 14) RESET BUTTON | Clears and resets the front panel controls in the event of a fault condition (reference Table 5.2) |
| 15) ANGLE INDICATOR | An Angle indicator for the Horizontal Axis of the Generator position. |
| 16) HAND SWITCH | A two-position switch that controls the x-ray output. The first position is for prep (ready) light goes out and comes back on when unit is prepped), the second position is for x-ray (x-ray light comes on while x-rays are being produced). Premature release of the exposure switch will terminate the exposure and light the fault lamp. Depress the RESET button to clear the fault and Reset the timer. |

NOTE: Internal fuses provide protection for auxiliary DC circuits; replacements should be made by Authorized Source-Ray Personnel only.

3.1 CONTINUED:

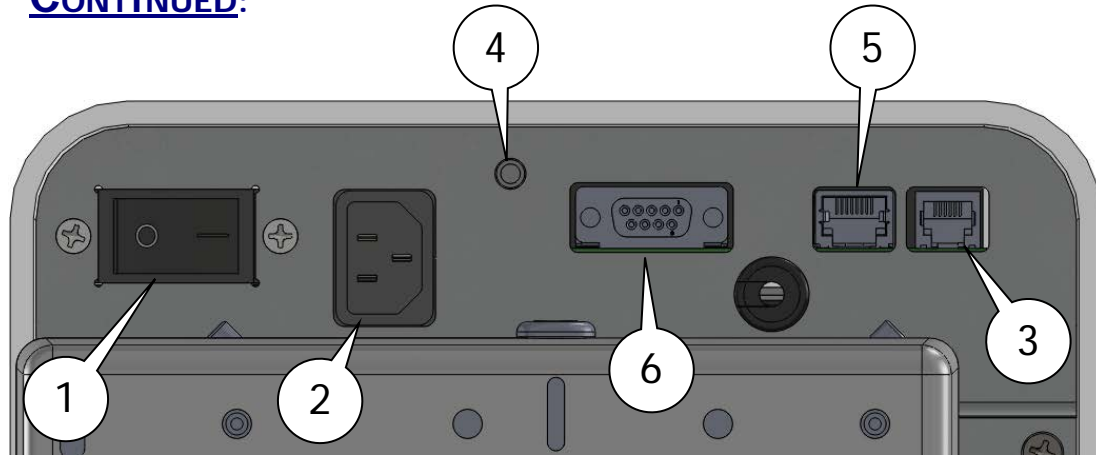


Figure 3.1

**Generator/Control Connector Descriptions
(Generator Bottom View)**

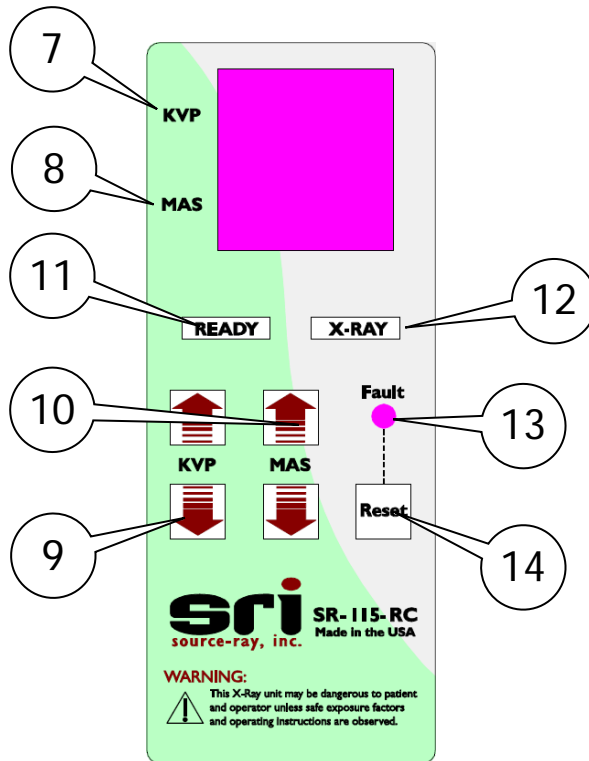


Figure 3.2

Optional Remote Control Panel Descriptions

3.1 CONTINUED:

mAs Increments								
0.20	0.45	1.00	2.20	5.00	11.00	25.00	56.00	125.00
0.22	0.50	1.10	2.50	5.60	12.50	28.00	63.00	140.00
0.25	0.56	1.25	2.80	6.30	14.00	32.00	71.00	160.00
0.28	0.63	1.40	3.20	7.10	16.00	36.00	80.00	180.00
0.32	0.71	1.60	3.60	8.00	18.00	40.00	90.00	200.00
0.36	0.80	1.80	4.00	9.00	20.00	45.00	100.00	
0.40	0.90	2.00	4.50	10.00	22.00	50.00	110.00	

TABLE 3.1
MAS INCREMENTS CHART

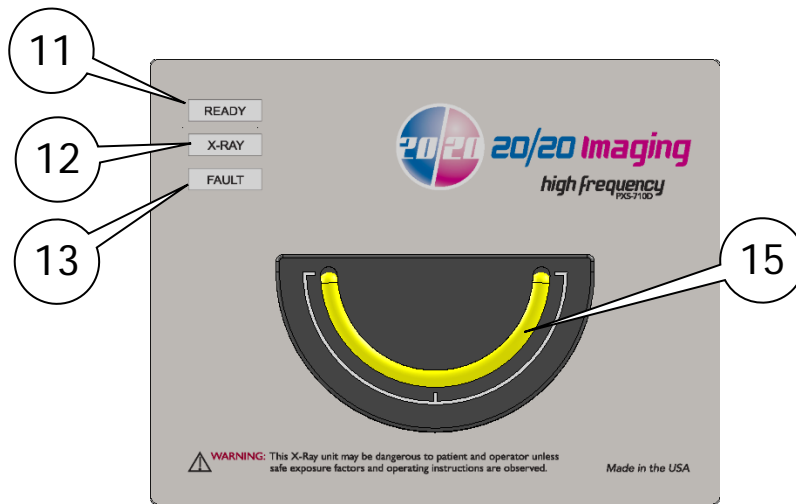


Figure 3.3
Control Panel Descriptions

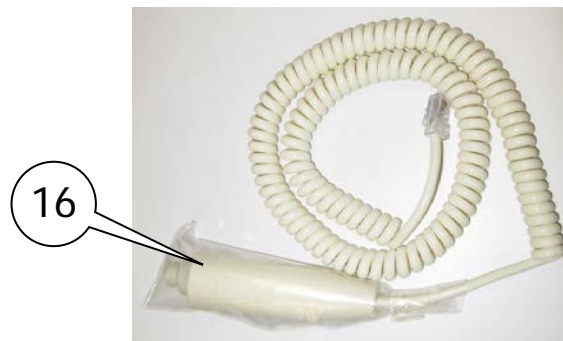


Figure 3.4
Hand Switch Assembly

3.2 SOURCE BASE

DESCRIPTION

FUNCTION

A. BOOM ARM

Controls the angle adjustment of the Generator/Control Assembly.

B. SHUTTER KNOBS

Adjusts X-Ray field size.

C. PATIENT SUPPORT RAIL

Functions as a support point for patients.

D. PATIENT BASE

Functions as positioning area for patient.

E. DETECTOR SLOT

Functions as a positioning slot for the 20/20 imaging detector. One is provided for Vertical alignment. Another is provided for Horizontal alignment.

F. COLLIMATOR LAMP

Left and Right buttons are provided on the Collimator. Depressing any button activates/de-activates the lamp, which is automatically extinguished after approximately 20 seconds to extend LED life.

G. SLIDE HANDLE

Slide Handle for Opening and Closing the Vertical DETECTOR SLOT.

3.2 CONTINUED:

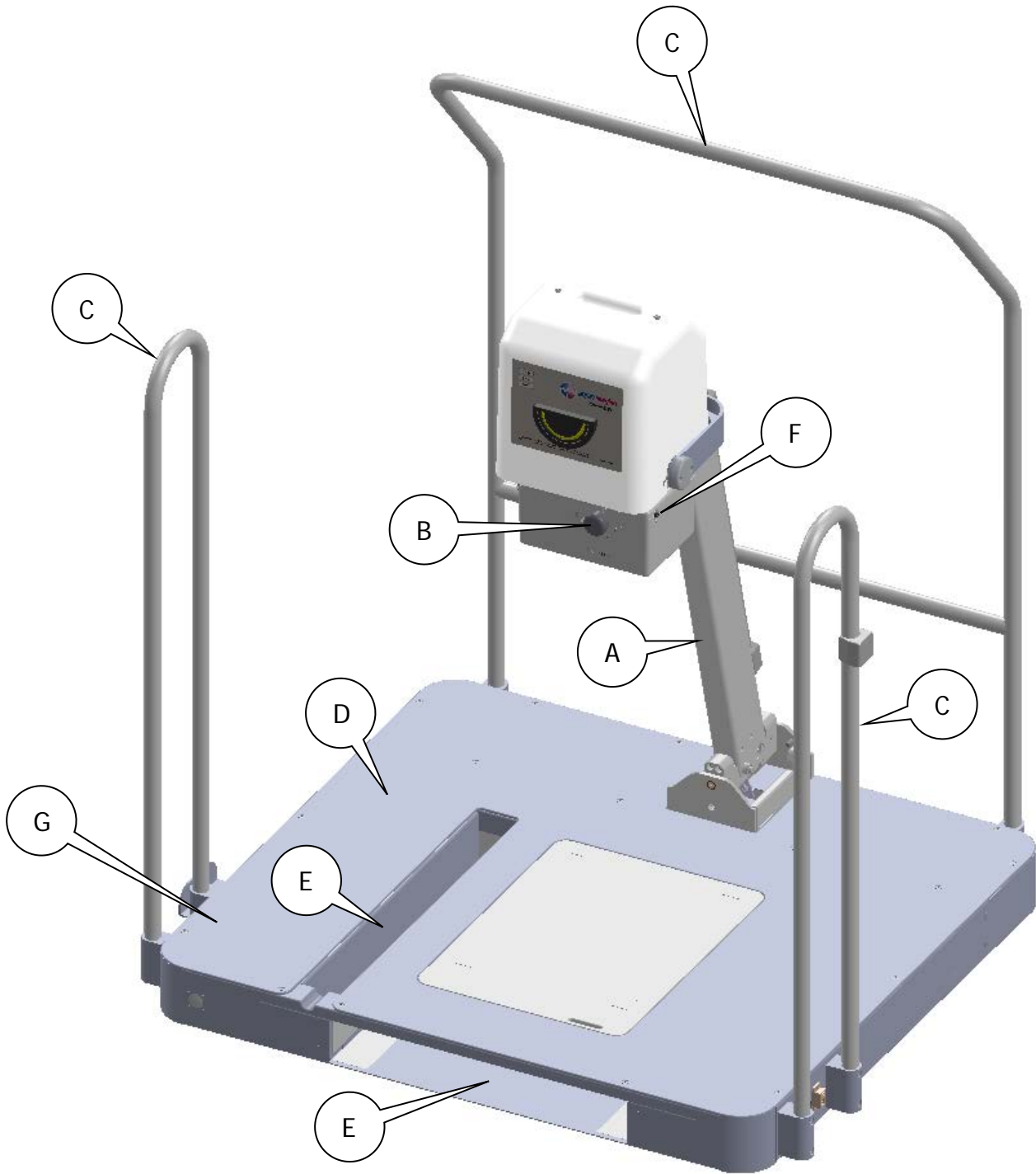


Figure 3.5
Source (Front View)

3.2 CONTINUED:

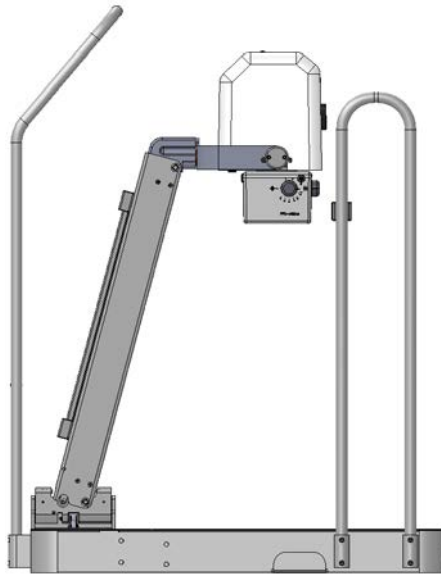


Figure 3.6

Source (Side View, 0° Head Tilt)

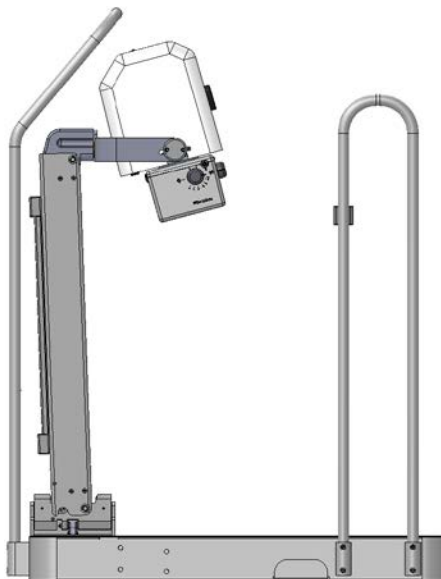


Figure 3.7

Source (Side View, 15° Head Tilt)

3.2 CONTINUED:

DESCRIPTION

FUNCTION

H. D.I.P. POWER SWITCH

Power Switch for the Digital Imaging Panel (D.I.P.) Supply(s). See **Section 3.1 (Item 1)** for X-ray Source Power Switch.

I. RS-232 CONNECTOR

Pass-Thru connector for the RS-232 port for Generator control by a Host Application. Provides connection to the Control/Generator RS-232 Port. DB9 FEMALE

J. REMOTE CONNECTOR

Pass-Thru Connector for the Optional SR-115-RC. Provides connection to the Generator/ Control's Remote port. RJ45

K. USB

Pass-Thru USB A-B Connector for the 20/20 Imaging Panel. Provides a USB 'B' type connector for connection to the 20/20 imaging panel.

L. POWER CONNECTOR

IEC C14 Style AC Power Input Connector.

M. GENERATOR CABLE

Fixed cables. Generator/Control cables.

N. 20/20 IMAGING PANEL P/T

Pass-Thru Cable Grommet for the 20/20 Imaging Panel cable assembly.

O. EXPOSURE SWITCH

Exposure Switch Pass-thru Connector. Connects to the Generator/Control's Exposure switch connector. RJ12

3.2 CONTINUED:

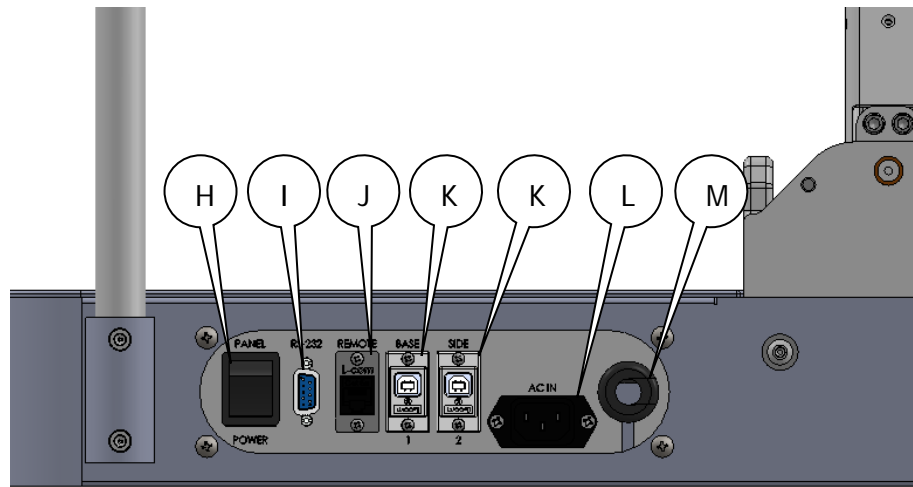


Figure 3.8

Source Base (Rear Connector Panel)

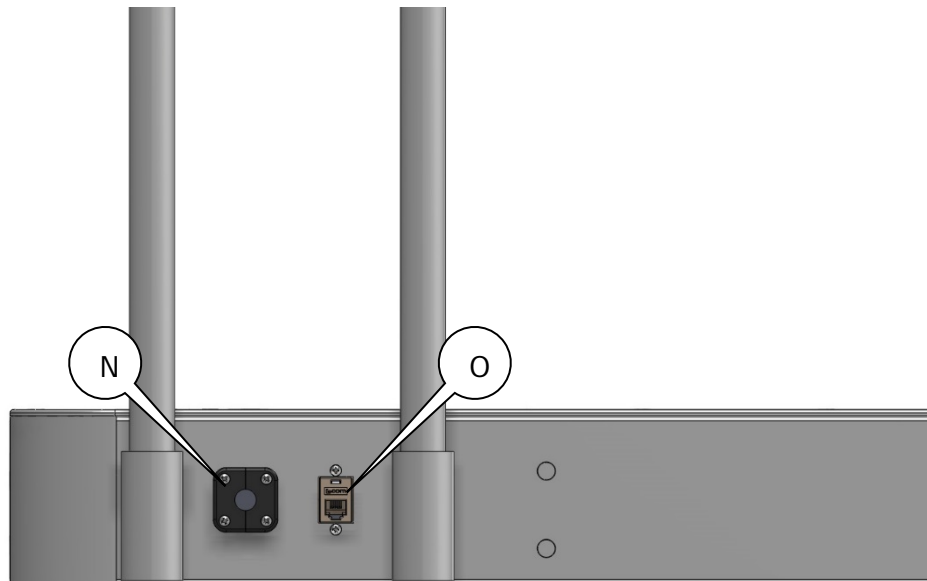


Figure 3.9

Source Base (Side Connector Panel)

3.3 OPERATING PROCEDURES: (GENERATOR/CONTROL ASSEMBLY)CAUTION

Do not attempt to connect or disconnect any interconnect cables without disconnecting the mains supply first.

3.3.1 MANUAL OPERATION (OPTIONAL SR-115-RC)

- 1) Operate the "Power On" switch (1) to turn the primary power on.
- 2) Activate the "**Collimator Lamp**" (G) by depressing one of the push-buttons located on the left or right side of the collimator. The collimator lamp will automatically extinguish after a period of approximately 15-30 seconds to extend bulb life.
- 3) Collimate the light field to the area of interest by means of the shutter adjust knobs.
- 4) Manually select the desired kVp by means of the kVp adjust switches on the optional Remote Control SR-115-RC (9).
- 5) Adjust the "**mAs**" to the desired interval by means of the mAs selectors (10). The resultant mAs is displayed on the mAs meter (8). Reference Table 3.2 for standard techniques.
- 6) After the required warm up period, the "**Ready**" Indicator will illuminate. It will not be possible to operate the unit until this has occurred. If the unit has not been operated for a long period of time an additional 2-minute waiting period is recommended.
- 7) While holding the "**Remote Exposure Control**", step at least 6 feet to side of side of the x-ray control/generator assembly.
- 8) Depress the "**X-Ray Switch**" to the first position (prep). The "**Ready Light**" will go off and come back on when the unit is fully prepped.

3.3.1 CONTINUED:

- 9) Depress the **"X-Ray Switch"** to the second position for immediate exposure. An audio tone will sound in addition to the **"X-Ray"** indicator illuminating for the duration of the exposure. Releasing the **"X-Ray"** switch prior to the pre-selected interval will terminate the exposure, light the **"FAULT"** Indicator and display a fault condition (Ref. Table 5.2).

NOTES:

- Unless the x-ray generator is going to be immediately used again, the "Power ON" switch should be turned off. Leaving the unit turned on provides opportunity for an accidental operation.
- If the unit is going to be operated again, an automatic inhibit circuit will allow the x-ray tube to cool in proportion to the exposure time to prevent damage to the x-ray tube from overheating. At the end of this cycle the **"Ready"** light will illuminate indicating an exposure can be made.

3.4 FAULTS:

The PXS-710D, when it encounters a Fault condition, will alert the user.

There are three ways a unit Fault may be displayed to the User.

- 1) Fault Indicator on Generator/Control Panel.
- 2) Fault Indicator on optional Remote Control SR-115-RC. A Fault Code is also displayed in the kVp display to indicate the fault. Ref Fig 3.3 & Table 5.2
- 3) Fault Reporting via the RS-232 Host Control interface. Please reference the PXS-710D Control interface documentation.

All Faults may be Reset by Cycling AC Power to the Unit.

- For Item #2, The Optional Remote Control Provides a 'RESET' button.
- For Item #3, a Command may be sent from the Host to reset the PXS-710D.

3.5 OPERATING PROCEDURE: (PODIATRY SUPPORT BASE)

- 1) Move the Boom Arm (A) to the desired position and release, the Boom Arm will retain the current position. The Boom Arm position range Left to Right is from -45° to 90° . Front and back position range is -2° to $+15^{\circ}$
- 2) To change the angle of the Generator/Control Assembly, Rotate the Generator/Control Left 15° or Right 15° , Detents will hold the Generator/Control in -15° , 0 , $+15^{\circ}$ increments.
- 3) To change the forward tilt of the Generator/Control Assembly, push the top of the generator back to move the X-Ray field forward. Detents are provided at 0° and 15° .
- 4) To Place the Customer Supplied Digital Imaging Panel in the Vertical Panel slot, pull on Slide Handle (G) to open Panel Slot, and insert the Digital Imaging Panel. Remove the Digital Imaging Panel and Push on the Slide handle (G) to Close the Panel Slot.

TABLE 3.2 (TECHNIQUE CHART)

XM3 PDR (Naomi): 400 speed.

Examination	Thickness	KVP	MAS	SID	Notes
Foot					
Dorso-plantar (AP)	Normal	55 -60	1.5	30"	
Lateral	Normal	55 -60	1.5	36"	
Marked Lesion	Normal	55 -60	1.5	30"	
Lateral Oblique	Normal	55 -60	1.5	36"	
Medial Oblique	Normal	55 -60	1.5	30"	
Axial Calcaneal	Normal	55 -60	4.5	30"	
Axial Sesamoid	Normal	55 -60	4.5	30"	
Harris and Beath	Normal	55 -60	4.5	30"	
Lewis	Normal	55 -60	3.0	30"	
Causton	Normal	55 -60	3.0	30"	
Ankle					
Anterior-Posterior	Normal	55 -60	3.0	30"	
Lateral	Normal	55 -60	3.0	36"	
Lateral Oblique	Normal	55 -60	3.0	36"	
Medial Oblique	Normal	55 -60	3.0	30"	
Mortise	Normal	55 -60	3.0	30"	
Stress Views (AP, lat)	Normal	55 -60	1.5	30"/36"	
Holly	Normal	55 -60	1.5	36"	
Isherwood	Normal	55 -60	1.5	36"	
Broden	Normal	55 -60	3.0	36"	

CR (Generic): 150 speed.

Examination	Thickness	KVP	MAS	SID	Notes
Foot					
Dorso-plantar (AP)	Normal	55 -60	5.5	30"	
Lateral	Normal	55 -60	5.5	36"	
Marked Lesion	Normal	55 -60	5.5	30"	
Lateral Oblique	Normal	55 -60	5.5	36"	
Medial Oblique	Normal	55 -60	5.5	30"	
Axial Calcaneal	Normal	55 -60	5.5	30"	
Axial Sesamoid	Normal	55 -60	5.5	30"	
Harris and Beath	Normal	55 -60	5.5	30"	
Lewis	Normal	55 -60	5.5	30"	
Causton	Normal	55 -60	5.5	30"	
Ankle					
Anterior-Posterior	Normal	55 -60	5.5	30"	
Lateral	Normal	55 -60	5.5	36"	
Lateral Oblique	Normal	55 -60	5.5	36"	
Medial Oblique	Normal	55 -60	5.5	30"	
Mortise	Normal	55 -60	5.5	30"	
Stress Views (AP, lat)	Normal	55 -60	3.0	30"/36"	
Holly	Normal	55 -60	3.0	30"	
Isherwood	Normal	55 -60	3.0	30"	
Broden	Normal	55 -60	3.0	30"	

- Nominal S.I.D. = 30in (761mm) (Reference Fig. 1.8)
- X-Ray Field Size @Nominal S.I.D.= 16.4" x 16.4" (416.5mm x 416.5mm)

HARRIS

Axial projection of the heel is useful for demonstrating talo-calcaneal bars. Patient stands with both feet on the film. The patient leans forward slightly. The tube is positioned behind the patient and the central ray is angled 45 degrees towards the heels and is centered between the medial malleolus.

LEWIS METHOD

The routine view of the Sesamoid bones of the first metatarsal.

ISHERWOOD METHODS (SUBTALAR REGION)

- 1) Projection to demonstrate the anterior subtalar articulation. Medial border of the foot at a 45-degree angle to the cassette. Center 2.5cm distal and 2.5cm anterior to the lateral malleolus.
- 2) Projection to demonstrate the middle articulation of the subtalar joint and give an end-on view of the sinus tarsi. Foot in the AP ankle position, rotate the ankle 30 degrees medially. Center to a point 2.5cm distal and 2.5cm anterior to the lateral malleolus with a 10 degree cephalad angulation.
- 3) Projection to demonstrate the posterior articulation of the subtalar joint in profile. Foot in the AP ankle position. Rotate the ankle 30 degrees laterally. Center to a point 2.5cm distal to the medial malleolus with a 10-degree cephalad angulation.

BRODEN I

Subtalar joint view. Foot positioned as for AP ankle, then rotate the foot 45 degrees medially. Angled the tube cranially between 10 degrees and 40 degrees.

BRODEN II

Subtalar joint view. Foot positioned as for AP ankle, then rotate the foot 45 degrees externally. Angle the tube cranially 15 degrees.

CAUSTON METHOD

Oblique foot projection to demonstrate the sesamoids. Position foot laterally, with the medial side against the cassette. Angle the central ray 40 degrees towards the ankle and center to the first metatarsophalangeal sesamoids.

THEORY OF OPERATION

4.1 SOURCE OVERVIEW

The Model PXS-710D incorporates one major electrical assembly, the Control/Generator Assembly. The Control/Generator Assy. consists of five sub-assemblies. The generator assembly houses the high voltage circuitry and the x-ray tube, high frequency generating circuitry, control electronics, microprocessor and a collimator (beam limiting device) assembly.

The PXS-710D also can be controlled via a RS-232 Serial link, the RS-232 Serial link allows a 3rd party computer application, OpalRad (Supplied by the End User), to communicate with the generator.

4.2 GENERATOR/CONTROL ASSEMBLY

The Generator Assembly is made up of High Voltage multipliers for the anode and cathode supplies, voltage feedback dividers, high voltage transformers and the filament transformer. For the Low Voltage section a Control Microprocessor PWA, Power Board PWA and the 24V power Supply are used.

The voltage used to generate the high voltage enters the assembly at pins **1 & 7** of connector P1. The voltage is approximately 650 VPP at an approximate 30 kHz square wave, for a 70-kVp output.

The filament voltage enters at pins **2, 4 & 6** of connector P1. Pin 4 is at a DC level of approximately 24V, and pins **2 & 6** have a high frequency voltage of about 48 VPP at approximately 50 KHz with respect to ground. Pin **3 & 5** of **P1** are ground connections.

Pin 9 of **P1** is the kV feedback signal (10 V=100kV). Pin **10** of **P1** is the cathode low-end signal (**10V = 10mA**). Pins **11** of **P1** provides the anode low-end signal, which goes to the mA test jack.

Connector **J3** (mA test jack) places a mA meter in series with the mA line for calibration purposes (Ref. Section 2.3).

4.2 CONTINUED:

The Power Board Inverter Assembly is powered by 115 VAC via connector **TB1** (ref dwg. 100206). With circuit breaker **CB1** closed, an AC voltage is applied through current limiting resistor **R1** of the Power Board PWA. The voltage is then rectified and filtered via Diode Bridge **D1** and Capacitors **C1 – C2**. The DC Voltage is used as the “Rail Voltage” for the High Frequency Drive to the X-Ray Generator. Relay **K1**, contacts **1A** and **1B** short resistor **R1**, on the Power Board PWA, during the **Prep** and **X-ray** period to allow the line to deliver the required power. Transistors **Q1** and **Q2** of the Control/Generator Assembly make up a full bridge high frequency circuit operating at approximately 30 kHz. This circuit is energized during the X-Ray On period and is used to convert the DC voltage back to high frequency AC to drive the high voltage transformer in the generator assembly (approx. 30 kHz).

The Control Board PWA provides commands to the Power Board PWA electronics for the kV reference, filament pre-heat, exposure time... and monitors the source for faults.

U15 of the Control Board PWA provides the High Frequency Drive for the High Voltage Supplies (anode & cathode), it drives the pulse transformer **T1** through signal FET's **Q4 & Q6**. Transformer **T1** drives the Gate of the IGBT's, **Q1 & Q2** located in the Power Board Assy.

U16 of the Control Board Assy. supplies the High Frequency Drive for the filament circuitry by driving FET's **Q8 & Q9** on the Power Board PWA. These FET's provide the High Frequency voltage for the filament transformer **T1** of the Generator Assy. Current transformer **T4** of the Power Board PWA monitors the primary current to the High Voltage Transformers and triggers timer **IC/U13** which sends a fault to the Microprocessor and shuts down the High Frequency Generator **IC/U15** which in turn shuts down the High voltage IC's.

4.2 CONTINUED:

IC/U18A (Over Voltage Comparator) and **IC/U17A & U18** (Over Current Comparator) shut the High Voltage down in the event of an over-voltage or over-current condition. A fault signal is also sent to the Microprocessor.

IC/U19 is the DC-DC converter that converts the 24VDC to +/-15VDC for the low voltage signal processing electronics.

Power Supply **A1** on the Power/Control Assy. provides the +24VDC for all electronic and microprocessor circuitry.

4.3 OPALRAD INVERTER ASSEMBLY

The RS-232 Serial Link allows a 3rd party application to control the Generator. Generator settings such as kVp, mAs can be set by the 3rd party application. The complete protocol is available from Source-Ray Inc. upon request. The following applications have been validated to operate with the PXS-710D:

Manufacturer	Product	UAI Version
Viztek	OpalRad	2.3.4.24

Table 4.1
Approved 3rd Party Control Software

The Serial hardware in the PXS-710D generator uses a 2.5KV Optically Isolated EIA/TIA-232E Compatible 3-wire interface. (Ref Figure 3.1 Item 6) This interface Operates at 19200 BAUD, 8N1. The Pin assignments are listed in Table 4.2

4.3 CONTINUED:

Pin #	Function Description	Signal
1	N/C	
2	TX	Output
3	RX	Input
4	N/C	
5	GND	Common
6	N/C	
7	N/C	
8	N/C	
9	N/C	

Table 4.2
RS-232 Pin Out

The Serial Protocol used in this interface incorporates a data packet with a 16-bit CRC for error detection. Handshaking ACK and NAK replies are incorporated to enable error recovery.

The Interaction of the OpalRad UAI (User Acquisition Interface) with the PXS-710D Generator is as follows: (REF. Figure 4.1)

The OpalRad UAI will be referred to as the 'Host'

GENERATOR IDLE:

When the generator is at rest, three (3) commands are recognized from the Host:

SETGENCMD	Sets the Generator Techniques
UNSETGENCMD	Revokes the Generator Techniques
ERRORSTATUSCMD	Requests the current machine status

- The SETGENCMD sets the Generator Techniques with the Data supplied in the data packet. When a user picks a technique button, this command is sent to the generator.
- The UNSETGENCMD revokes any set techniques by setting them to zero. This is sent to the generator when a Technique button is de-selected.

4.3 CONTINUED:

- The ERRORSTATUSCMD Request is used for retrieving the Generator Techniques and obtaining Error information. It is also used to verify the Generator is properly connected and powered ON.

The OpalRad UAI will process any Errors returned and display them to the User. These Errors are outlined in Table 5.2

GENERATOR PREP:

If the generator enters the PREP state the following command is sent to the Host:

PREGENCMD Indicates to the host the PREP switch is activated.

When the User depresses the PREP switch, the generator sends a PREGENCMD to the Host. This will alert the Host that the User is attempting to start the expose process. The Host will then Display a READY Icon to alert the User that a 2 second x-ray Tube filament heating time is in progress. After 2 seconds the Icon turns GREEN, indicating to the user that an exposure can be made.

During the PREP and the following XRAY state, the Generator will not accept any commands and the set Techniques cannot be changed.

GENERATOR XRAY:

During the Exposure process, the following commands are sent to the Host:

XRAYINDCMD Indicates to the Host a X-Ray indicator is to be displayed.

POSTGENCMD Indicates to the Host an exposure has completed.

When the User proceeds to depress the XRAY switch the generator sends a XRAYINDCMD to the Host. The Host then displays a X-RAY Icon to indicate to the User an exposure is in progress.

The Generator will then make an exposure with the Techniques set in the Generator Idle state.

4.3 CONTINUED:

If an Error Occurs or the User releases the PREP and/or XRAY switches the Exposure terminates. Otherwise the Exposure completes normally with the Techniques that were set.

Once the Exposure is completed, a POSTGENCMD is sent to the Host. The POSTGENCMD contains the Techniques used for the exposure including Time. If the exposure terminated prematurely, the POSTGENCMD reports the actual exposure time and returns the Error that caused the termination.

After the Exposure and when the User has released the PREP and XRAY switches, the Generator returns to the Generator Idle State.

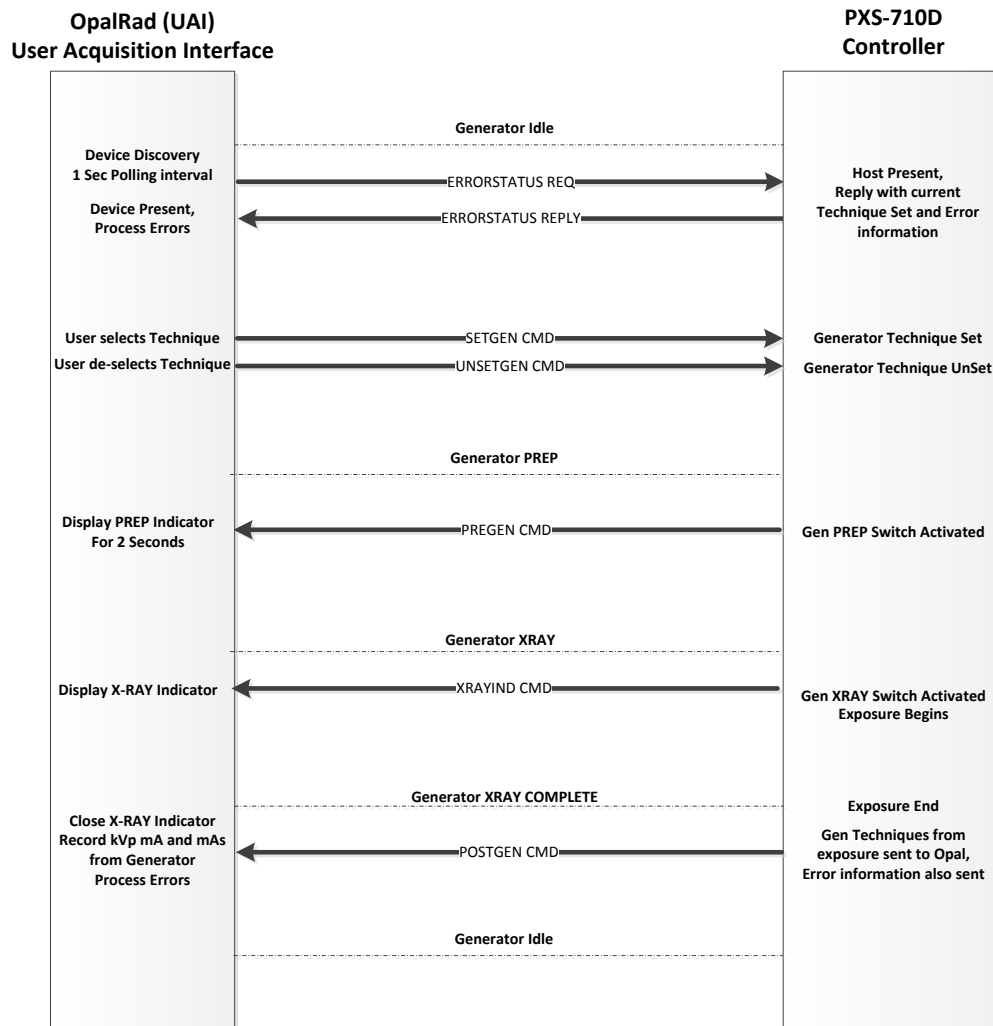


Figure 4.3

Generator OpalRad Communications

UNIT MAINTENANCE

CAUTION

This section pertains to authorized Source-Ray service personnel only

Equipment installation and servicing procedures should be performed by properly trained and qualified service personal only.

Protective covers are provided to shield service personal from inadvertent contact with high voltage components.

Electrical shock hazard! The HF Series X-ray Generator contains the serviceable components. Do not attempt to disable these components or remove any trim covers. Refer service to qualified service personnel.

5.1 INTRODUCTION

In order to keep this Source-Ray unit operating properly, it must be inspected and checked in accordance with the recommended intervals depending on the age and use of the equipment. If there is a problem, call an authorized serviceman.

DO NOT OPERATE THE EQUIPMENT UNTIL REPAIRS ARE COMPLETED.

5.2 RECOMMENDED INTERVALS

Periodic preventive maintenance including cleaning, mechanical and electrical adjustments, are to be performed every **six months** or 3000 exposures. Calibration intervals should not exceed 12 months. The periodic maintenance schedule is required to maintain the unit in proper and accurate working condition. Service life of unit is 5 years.

5.3 ORDERING INFORMATION

To order replacement parts contact your local authorized Source-Ray dealer. Authorized Source-Ray dealers should contact the main office at (631) 244-8200 between the hours of 8:00 AM and 5:00 PM. When ordering replacement parts be prepared to submit the following information: purchase order no. (If possible), Source-Ray part number, part description, quantity required and shipping instructions. If replacement parts are for a unit under warranty be prepared to submit model numbers and serial numbers to expedite your order.

5.4 MAINTENANCE PROCEDURE

Reference the checklist on following page.

The PXS-710D contains no user serviceable parts.

5.5 WARM-UP PROCEDURE

If equipment has remained un-powered for an extended period of time, it will be necessary to bring the unit up slowly so that the high voltage circuits are not damaged.

- 1) No patient should be present during Warm-Up procedure.
- 2) Completely close shutters on the collimator.
- 3) During X-ray exposure operator should be located in a safe distance outside the x-ray field, governed by the regulations and requirement of every state.
- 4) Turn the unit on and set the following; 60 kVp, Low mA and 10 mAs.
- 5) Take a 2 – 3 exposures.
- 6) Increase kV by ten and repeat step 3.
- 7) Repeat steps 2 and three until you reach the 110kV setting.

**TABLE 5.1
MAINTENANCE CHECKLIST (EVERY SIX MONTHS)**

MODEL: PXS-710D

SERIAL # _____

- 1) Beam Current (Reference Section 2.3) _____
- 2) Tube Potential (Reference Section 2.4). _____
- 3) Exposure time (Reference Section 2.5). _____
- 4) Beam Alignment (Reference Section 2.6) _____
- 5) Check voltage on X-Ray Generator at J2 pins A and B
(collimator supply) with collimator unplugged (24 VDC). _____
- 6) Check that all Indicator lights are operating. _____
- 7) Check that all hardware is tightly secured, tighten if required. _____
- 8) Check that collimator-mounting ring is tight. _____
- 9) Check all interconnect cables for broken or frayed wires. _____
- 10) Check that all hardware is secure and properly fastened. _____
- 11) Check that all friction locks (head rotation) are properly
adjusted, tighten as required. _____
- 12) Inspect spring mounts. Make sure all mounting
hardware is secure. (tighten if required) _____
- 13) Inspect spring strength, if unit drifts down when lock is not
engaged, replace piston. _____

NOTES:

- When cleaning, use a cloth moistened in warm soapy water (use mild soap). **Do not** soak the unit and **do not** use strong cleaners or solvents as they may blur the lettering or dull the finish. Polish with pure liquid or paste wax.
- Do not use a wax containing a cleaning substance. Do not polish the meter windows.

SERVICE ENGINEER: _____

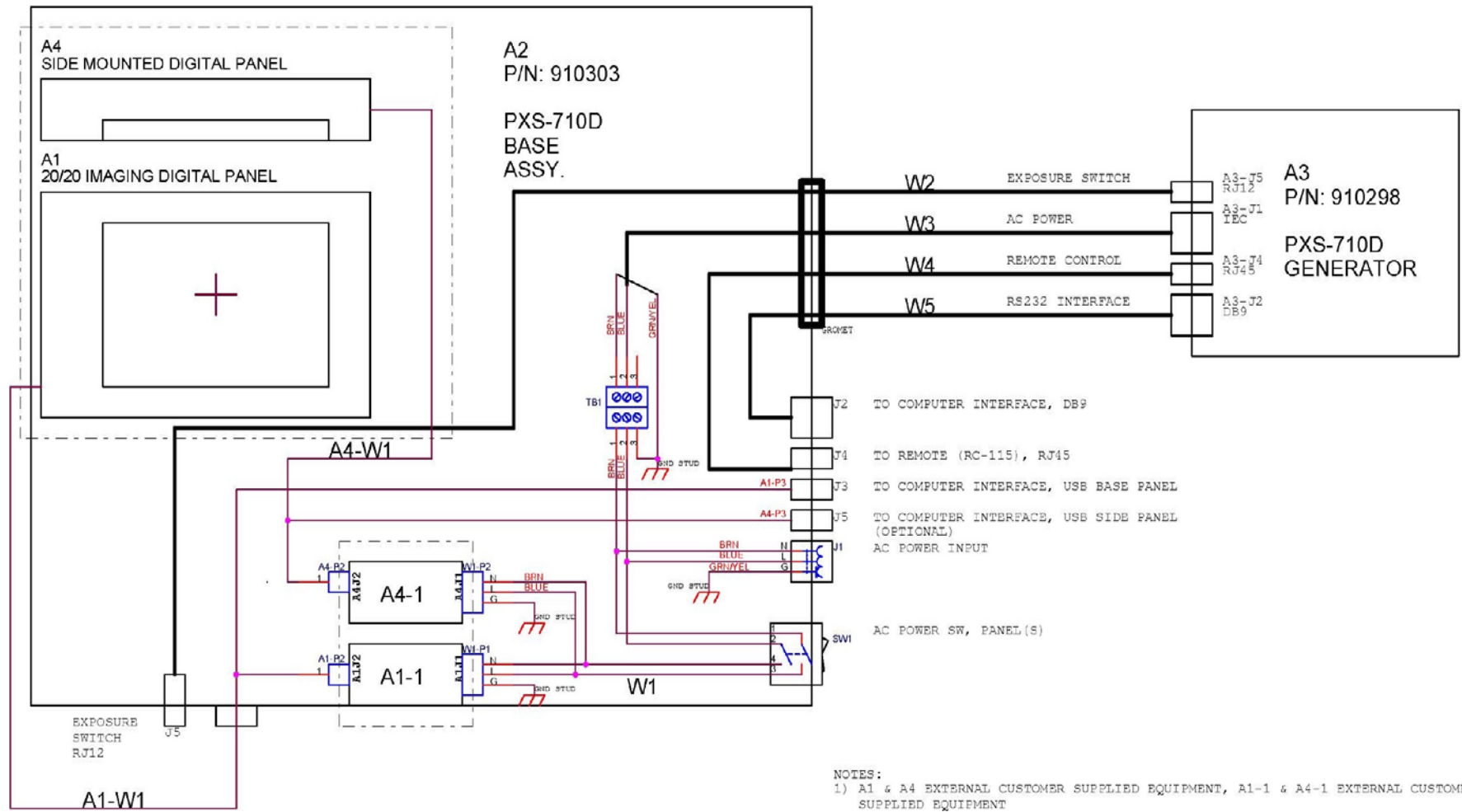
DATE: _____

TABLE 5.2
DISPLAYED FAULT CONDITIONS

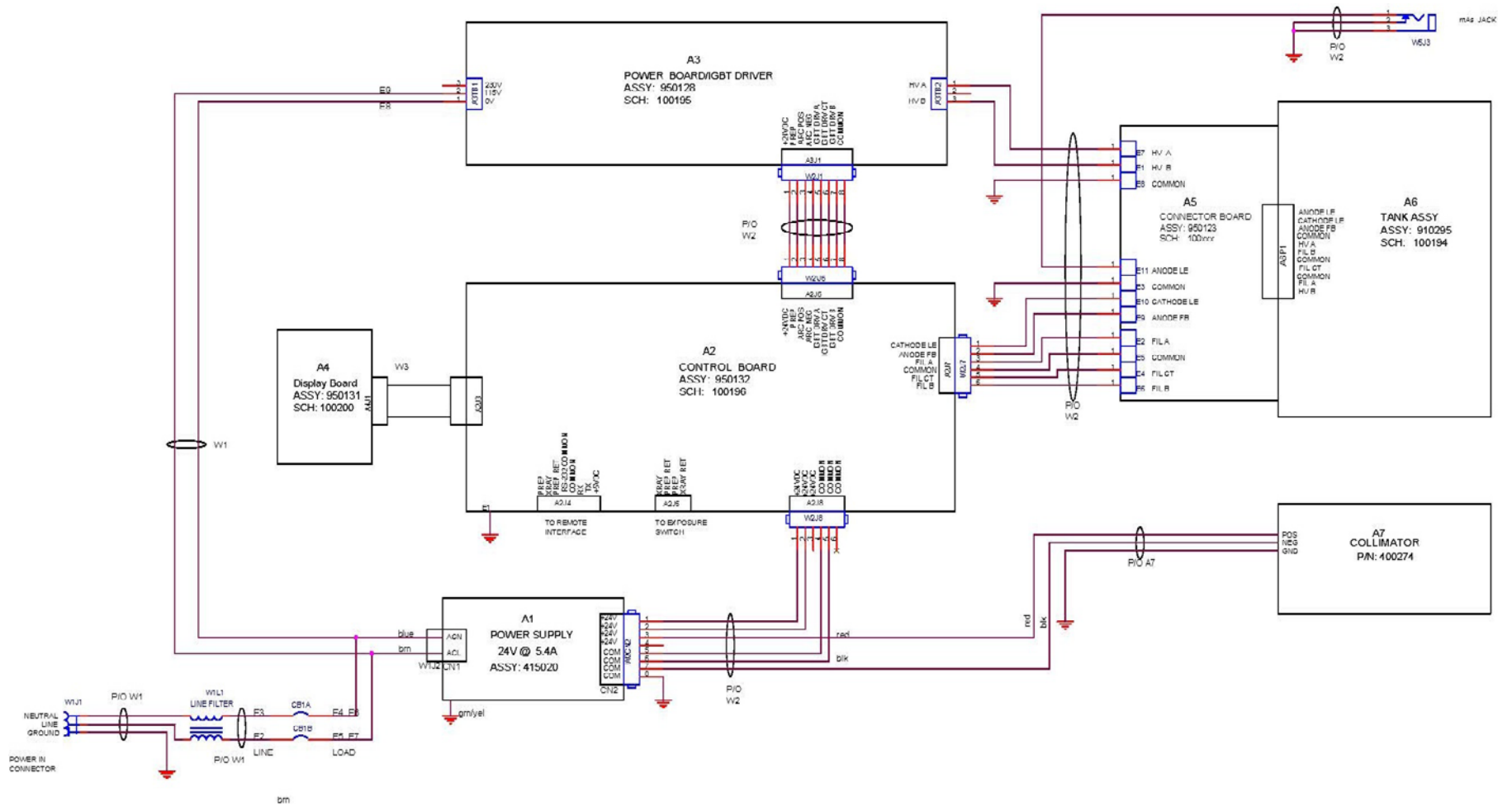
<u>DISPLAY</u>	<u>FAULT DESCRIPTION</u>	<u>ACTION REQUIRED</u>
1	Inverter Fault.	Reset Unit (1), Call for Service
2	No or low mA signal during exposure	Call for Service
3	Exposure terminated by operator	Reset unit
4	Stuck or shorted exposure switch.	Check or replace switch.
5	Reserved	
6	Reserved	
7	Reserved	
8	Exposure watchdog failure	Call for Service
9	Flash CRC Error	Call for Service
10	RAM Memory Error	Call for Service
11	EEPROM CRC Error	Call for Service
12	EEPROM Write Error	Call for Service
13	Serial Communications Error	Reset unit
14	Stuck or Shorted Prep Switch	Check or replace switch.

LIMITED WARRANTY

Source-Ray, Inc. warrants its Model PXS-710D Podiatry X-Ray Source to be free of manufacturing defects, which can impair their normal operation when used within their specified ratings. Claims under this warranty must be made within 3 years after shipment from the factory. Such warranty shall not apply to defects resulting from accidents, alterations, abuse or misuse. X-Ray Tube and Collimator warranty is limited to that provided by the manufacture (one year). Liability under this warranty is limited to repair or replacement of defective components at the factory. ***Shipping costs are not included.*** This warranty is in lieu of any other warranty expressed or implied. Collimator LEDs, exposure cord assemblies, interconnect cables and tires are considered normal wear and tear and are not covered under this limited warranty.



SCHEMATIC 5.1
BASE WIRING DIAGRAM (100208_2)



SCHEMATIC 5.2
GENERATOR WIRING DIAGRAM (100206_1)